



REPLACING WOOD FOR GOOD™

INSTALLATION GUIDE



A look is worth a thousand **wows**.



Accessing Our Training Videos

- Throughout this manual, you will see QR codes that will allow you to view training videos on a variety of installation subjects. .
- You can access the videos from any computer, tablet or smartphone 24/7.
- Simply use your smartphone or tablet camera app to scan the QR codes throughout this manual.

Note: You can also access the video by clicking on the link or by visiting the website listed next to each QR code..

Test using the QR code below:



Or view the video at:

<https://deephow.ai/p/KgDb2aJ3zsU1r1DZ1FtY>

Navigating This Manual

For ease of navigation, each Table of Contents contains shortcuts that let you go directly to your desired section by clicking on the subject.

Comments, ideas, suggestions?

Contact us at (937) 726-6268 or david.verbofsky@cornerstone-bb.com

deephow

* The way individuals learn has changed dramatically. Understanding the common challenges with learning and development are imperative in understanding how to reshape training strategies to create a better experience. Through an AI-powered learning platform based on interactive how-to videos, **DeepHow-via-StanleyX** allows organizations to create connected relevant material that is aligned with needs of learners, bridging the skills gap in manufacturing, and service and repair.

PVC Trim Installation



Installing PVC trim*

<https://deephow.ai/p/7SW9SBigVLosg3FhEj62>



PVC trim offerings and accessories*

<https://deephow.ai/p/VWXPLyXzhUeDcCGZ9aZo>

General Topics 5

Storage and Handling.....	5
Cleaning.....	5
Safety.....	5
Cutting.....	6
Drilling.....	6
Routing.....	6
Fastening.....	7
Expansion/Contraction.....	10
Sealants and Adhesives.....	12
Spanned Applications.....	15
Ceilings and Soffits.....	15
Filling Nail Holes.....	16
Painting.....	16
Heat Bending.....	17

Specific Applications..... 20

Outside Corners.....	20
Flanged Outside Corner Posts.....	21
Flashing Windows.....	22
Window & Door Trim.....	24
Picture Framing.....	25
Skirt Boards.....	28
Post Wraps.....	29
Garage Door Trim.....	30

Industry Terminology..... 31

Navigating This Manual

To go directly to your desired section, click on the subject in the Table of Contents.

NOTES

PVC Trim

STORAGE AND HANDLING / CLEANING / SAFETY

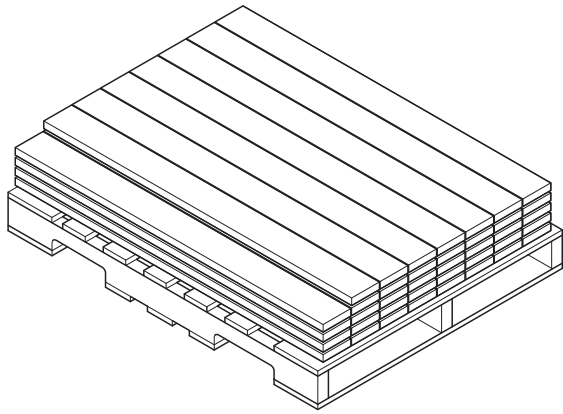

How to clean, finish & paint PVC trim*

<https://deephow.ai/p/Uj1DHFy9m5IOSBDs1YJQ>

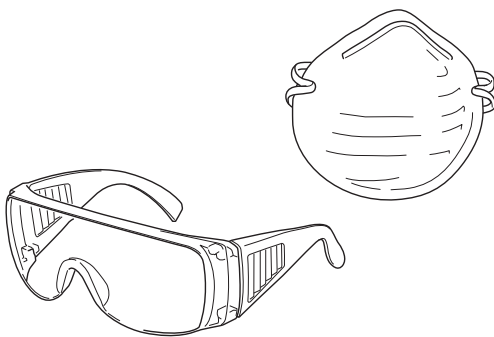

Storage and Handling

- Store on a flat level surface.
- Stack evenly and use a pallet shroud or tarp when storing outside. If product gets dirty, clean with a soft brush and mild cleaner.

Note: Do not store or place on asphalt or in areas prone to excessive heat buildup. Handle with care to avoid damage.

Units are shipped in tough film-faced plastic wrap to protect them from dirt and debris. Film facing is not meant to be a weather barrier.

Cleaning

- Clean with a soft bristle brush and a mild soap and water mixture. Test any cleaner on an inconspicuous area before you use it.
- For stubborn stains or to get dirt out of the cells, use a nylon brush.

Safety Precautions

Cutting will create PVC dust and particles.

- Cut cellular PVC trim in an open, well ventilated area.
- Always wear safety glasses or goggles and a face mask when cutting.
- If cutting with power saw, wear a dust mask.
- Refer to MSDS for additional safety information.

Note: Ply Gem Trim and mouldings are not to be used as structural products in load-bearing applications. PVC boards must always be supported by wood or other structural materials.

PVC Trim

CUTTING / DRILLING / ROUTING

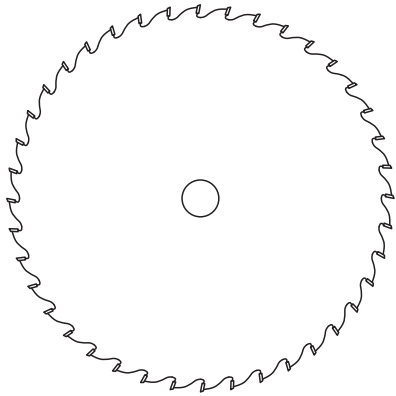

**USE CARBIDE TIPPED BLADE
(32-TOOTH OR HIGHER)**

**USE STANDARD
WOODWORKING
DRILL BITS**

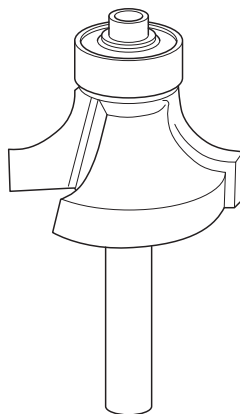
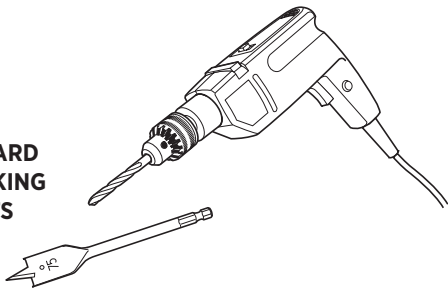

Cutting

Ply Gem Trim and Mouldings can be cut with standard carpenter's tools.

- Use carbide-tipped blades (32-tooth or higher). Avoid blades designed for plywood or metal.

Note: blade should be mounted in "normal" orientation, NOT reversed as when you are cutting vinyl siding.

- Rough edges can result from excessive friction, poor board support, worn blades or poor alignment.
- Rasp and sand to restore a smooth edge.

Drilling

Use standard woodworking drill bits. Do not use bits made for rigid PVC.

- To prevent heat buildup, remove excess shavings frequently.

Routing

- Use a sharp carbide-tipped bit.
- Align the router guide bearing along a smooth cut.
- If necessary, go over the cut a second time to smooth the surface.
- Sand with 320 grit sandpaper.

PVC Trim

RECOMMENDED SCREWS / NAILS

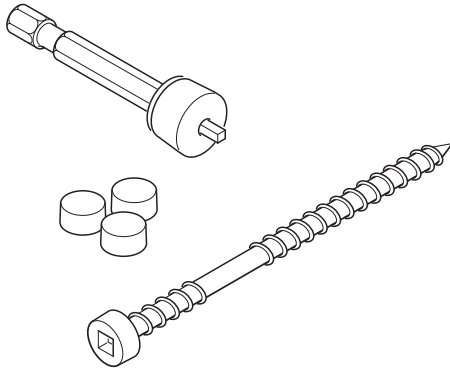

Recommended Fastener Screws

Fasten with stainless steel screws to prevent corrosion, though galvanized screws are acceptable. Do not use staples, brads, wire nails, fine-threaded wood screws or ring-shank fasteners.

Two industry-proven fasteners are:

- Cortex® Screw Plug System with plugs matching Ply Gem Trim.
- OSI® TrimTeQ System with plugs matching Ply Gem Trim.

Note: Please follow the manufacturer's recommendations as to required length of these specialty fasteners.

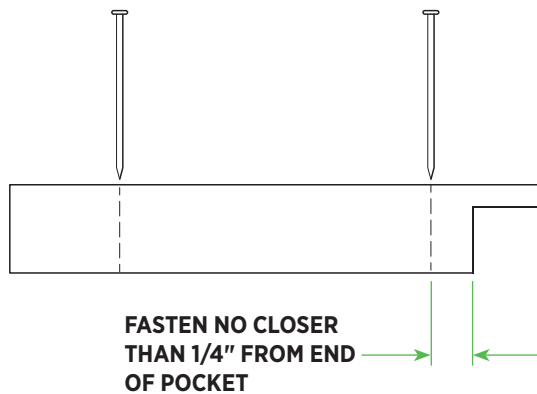

Recommended Fastener Nails

- Fasten with stainless steel or galvanized nails (wood siding nails, box nails, etc.). Nail guns can be used but don't over drive the nail into the trim.
- Standard nail guns work well with Ply Gem Trim and Moulding products. If using pneumatic tools, the air pressure should be regulated so fasteners slightly penetrate the surface (typically between 70psi-100psi depending on fastener and equipment being used). An in-line pressure gauge will help maintain even pressure to the nail gun.

PVC Trim

FASTENING SCHEDULE

Fastening Schedule (to be Applied Every 16" on Center)*

Product	Actual Thickness	Board Width	Number of Fasteners Per Width	Minimum Fastener Length
Trim Boards	5/8" or over	4" & 6"	2	2-1/2"
	5/8" or over	8" & 10"	3	2-1/2"
	5/8" or over	12"	3-4	2-1/2"
Sheets	1/2" or less	48"	16" on center horizontally 6" on center vertically 4" around perimeter of panel	2"
	5/8" or over	48"	16" on center horizontally 6" on center vertically 4" around perimeter of panel	2-1/2"
Skirt Board	1"	6"	2	2-1/2"
	1"	8"	3	2-1/2"
Beadboard	1/2"	6"	2	2"
Outside Corners	1"	4" & 6"	2	2-1/2"
Inside Corners	1-1/2"	1-1/2"	2	3"

*Recommended sizes assume that product is applied over structural sheathing with a thickness of at least 1/2" applied directly to a framing member. If non-structural sheathing is used, the fastener must penetrate through the sheathing into the framing member a minimum of 1-1/2".

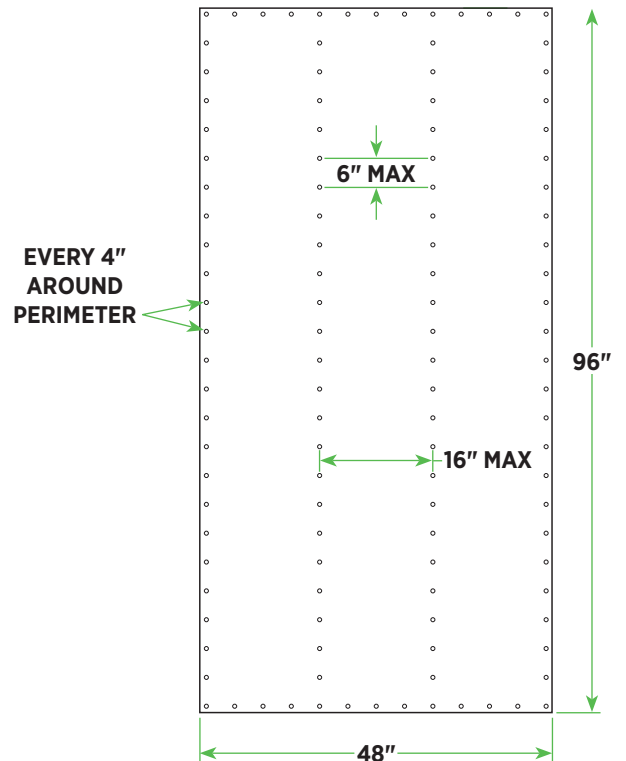
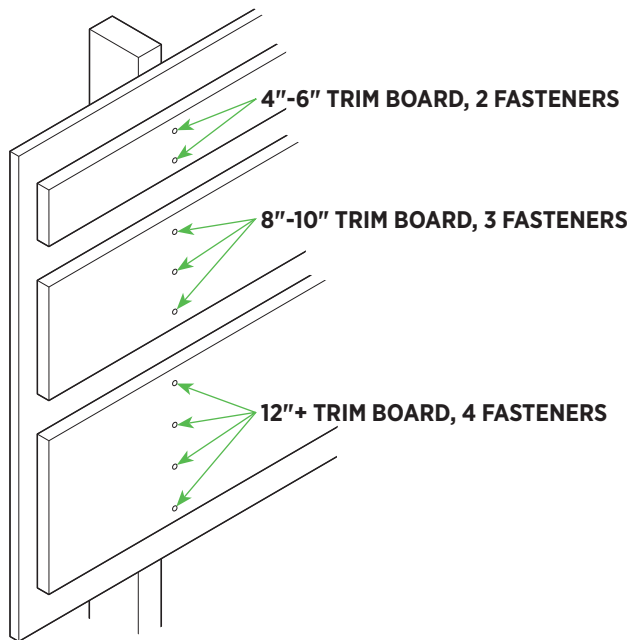

PVC Trim

FASTENING

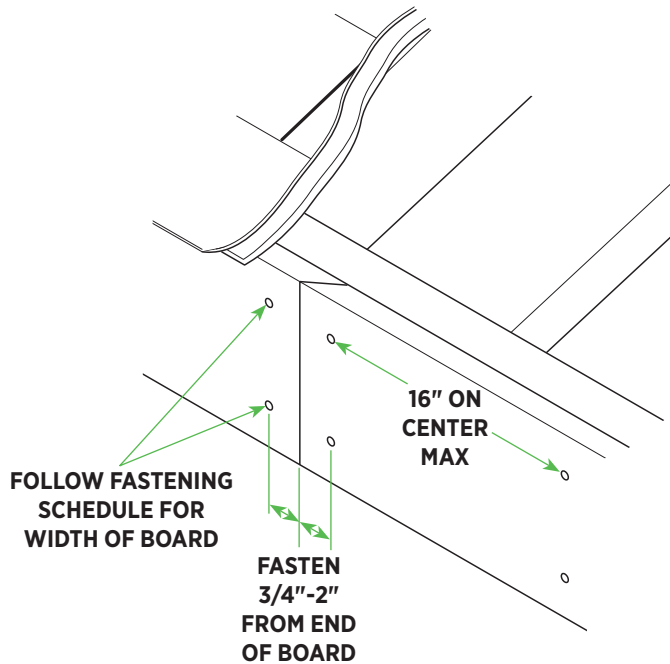

Fastening

- Nails should penetrate 1-1/2" into solid wood substrate. If using screws, please see "Recommended Fastener Screws."
- When covering non-structural sheathing (1/2" foam), fasteners should be long enough to penetrate solid substrate a full 1-1/2".
- When covering 1/2" OSB, fasteners need to penetrate substrate only 1".
- Fasten no closer than 3/4" from end of board and no further than 2" from end of board.
- If framing members are greater than 16" on center, provide additional bracing for fastening.
- Fastener heads should be flush with the surface of the trim or slightly indented.
- Pre-drilling typically is not required unless large fasteners are used or the temperature is below 40°F.

PVC Trim

FASTENING MOULDINGS / EXPANSION AND CONTRACTION

Fastening Mouldings

When applying smaller, lighter pieces like base cap, quarter round, head flashing or bed mould, use a smaller fastener such as a 4d finish nail. Pre-drill holes if necessary. Where greater holding power is required, use adhesive or glue.

Expansion and Contraction

Cellular PVC trim products expand in warm temperatures and contract in cool temperatures. This movement is ONLY an issue on longer runs of multiple 18' boards. For example, on rakes, fascia or frieze. Short lengths, such as window trim, can and should be built with tight joints.

PVC Trim

EXPANSION AND CONTRACTION ON LONG RUNS

PVC TRIM TO PVC TRIM

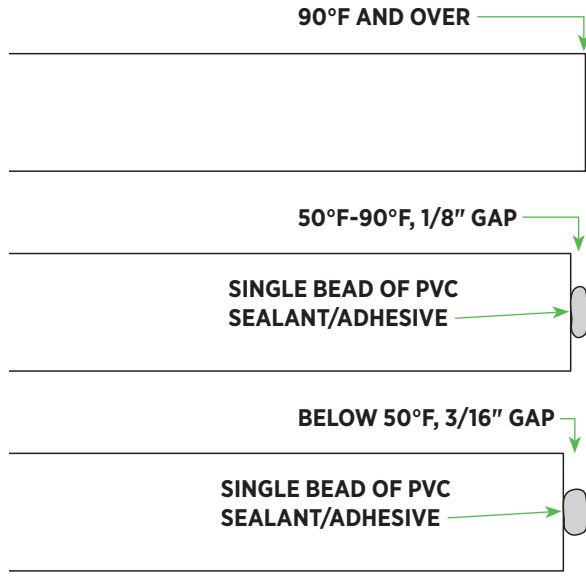

Leaving an Expansion Joint with Long Runs

Leave a gap per 18 feet of run at ends of boards or at inconspicuous joints for expansion and contraction. Never completely fill the joint with sealant.

Application temperature and appropriate gapping:

- 90°F & higher Install tight
- 50°F to 90°F 1/8"
- 50°F and below. 3/16"

SIDING TO PVC TRIM

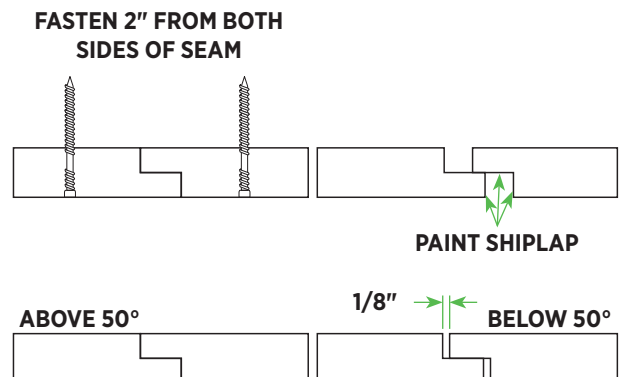
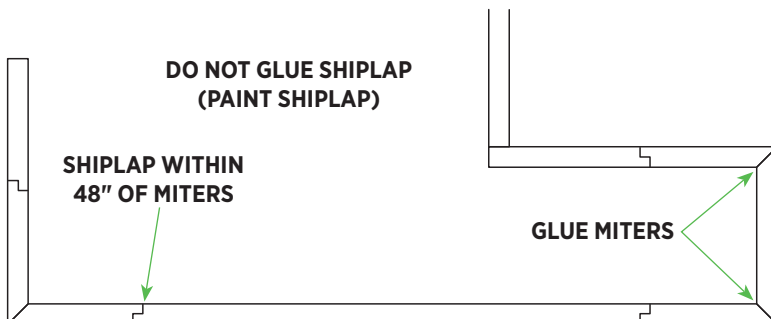
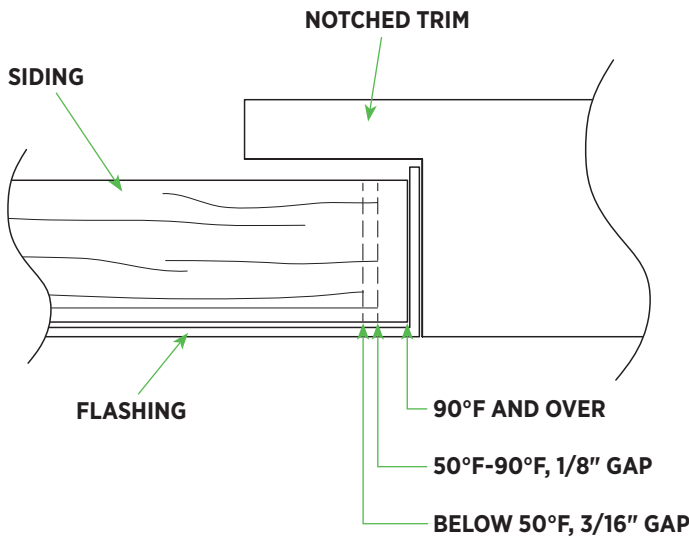

PVC Trim

SEALANTS AND ADHESIVES

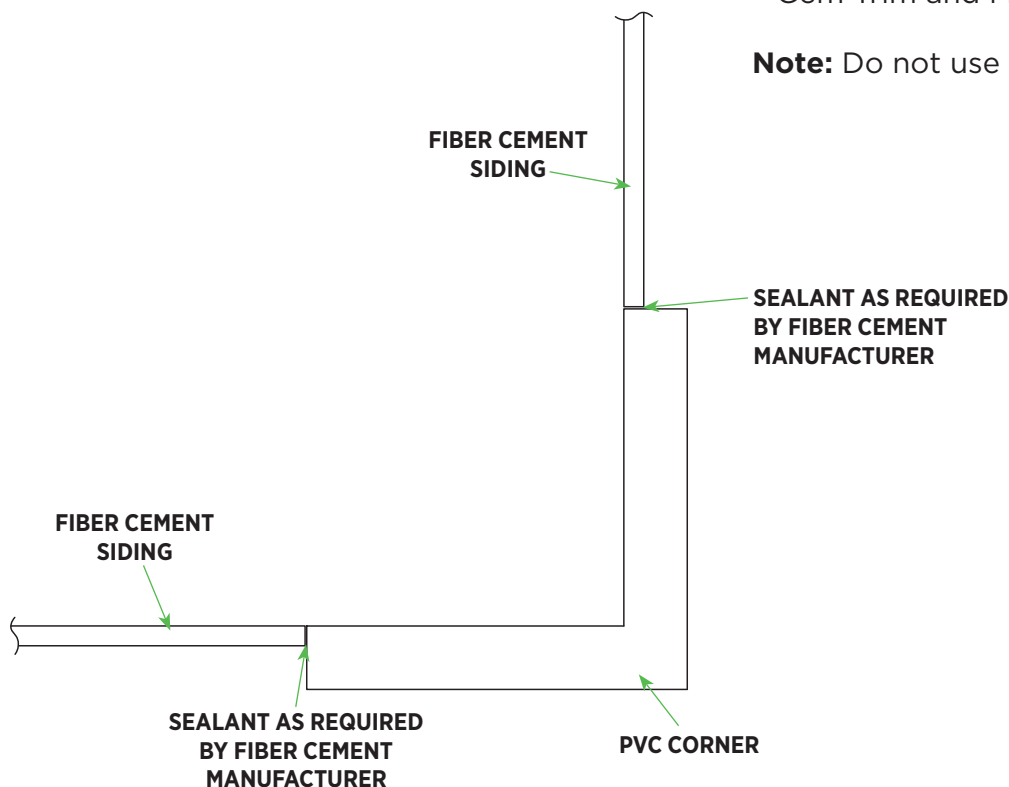
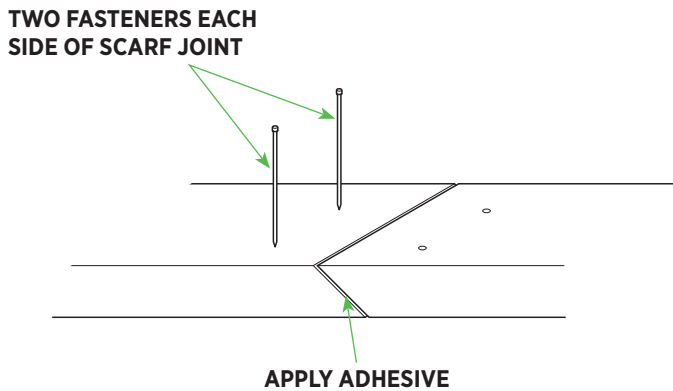
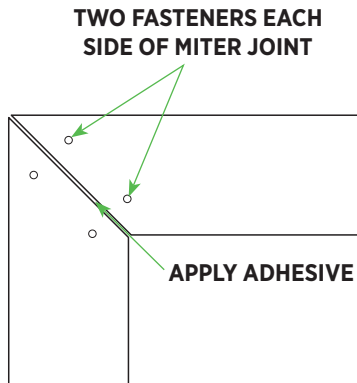

Sealants and Adhesives

Two-component adhesives designed specifically for cellular PVC are readily available and provide the strongest available bond. One-part PVC cement may be used but it offers less working time and adhesive strength.

- Two industry-proven adhesives:

Extreme Adhesive PVC TrimWelder™ Fill & Flex PVC

(Fast Cure, Slow Cure, White Hot)

Bond & Fill® Structural

(Fast Cure, Slow Cure, Quick & Easy)

- Use adhesive on one board and slide the secondary board into the adhesive bead creating cohesion of the two boards.
- Bonded joints should be secured with fasteners on each side of the joint.
- Never use adhesives alone for attaching Ply Gem Trim and Mouldings to substrate.

Note: Do not use silicone.

PVC Trim

BONDING TRIM TO VARIOUS MATERIALS

Note: With all applications it is critical to use fasteners and follow the fastener spacing requirement chart.

Bonding Ply Gem Trim to Itself

- PVC TrimWelder by Extreme Adhesives

Bonding Ply Gem Trim to Wood

- Liquid Nails Subfloor or Heavy Duty Construction adhesive
- NPC Solar Seal 900
- Polyurethane based adhesives (PL's or equivalent)

Bonding Ply Gem Trim to Metal

- PVC TrimWelder two component methacrylate by Extreme Adhesives with the use of fasteners

Bonding Ply Gem Trim to Concrete or Block

- PVC TrimWelder by Extreme Adhesives
- NPC Solar Seal 900

Note: Most PVC cements cure in 3-5 minutes and have a limited working time.

Note: Always test sealants and adhesives for compatibility before applying.

PVC Trim

CONTROL MOVEMENT AT JOINTS / HIDING EXPANSION JOINTS

SHIPLAP

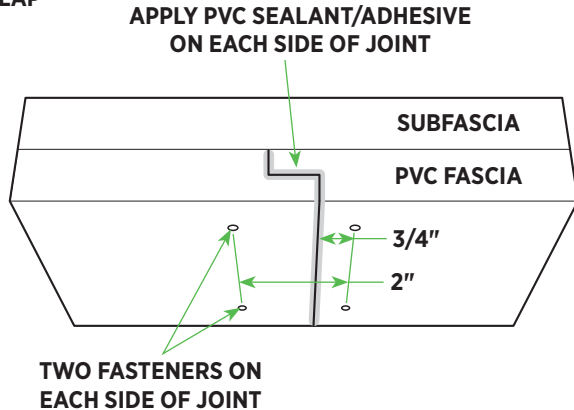

45° MITER CUT/SCARF JOINT

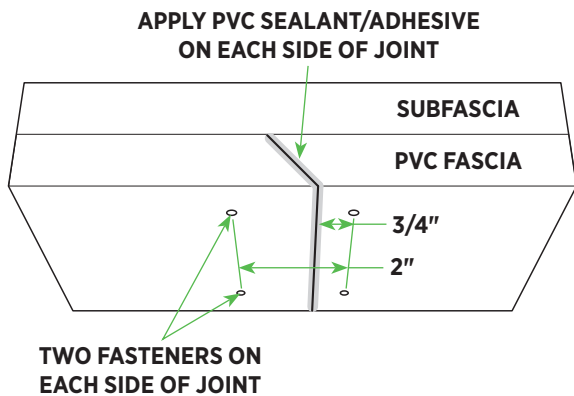

Control Movement at Board Joints

Glue the joints, using a one part PVC cement or a 2-part PVC adhesive at joints, especially in high traffic areas. Gluing the joints moves expansion and contraction out to the ends of the run.

- Join boards with shiplap or 45-degree miter joints. Do not butt joints. Glue boards together with one part PVC cement or a 2-part PVC adhesive.
- Double fasten on both sides of joint (screws work best). Use recommended number of fasteners based on width of boards (see "Fastening Schedule").
- To further restrict movement on longer runs, reduce on center fastening to 12".
- Southern exposure, or areas where product is in direct sunlight, can result in greater movement. Use more fasteners and/or wider expansion joints.
- Expansion/contraction joints should be placed at ends of run or in inconspicuous areas.
- Allow Ply Gem Trim to acclimate to outside temperature before installing. Ideally, install long runs when temperature is 60-70°F.

Hiding Expansion Joints in Long Runs

Hide expansion joint by controlling one end of the run and allowing room for expansion and contraction at the other end.

- By using this technique in the illustration, the left side board is creating a gap allowing that board to expand and contract based on temperature at the time of installation. The right board will dead end to the left board closing off the gap and not seen from the ground.

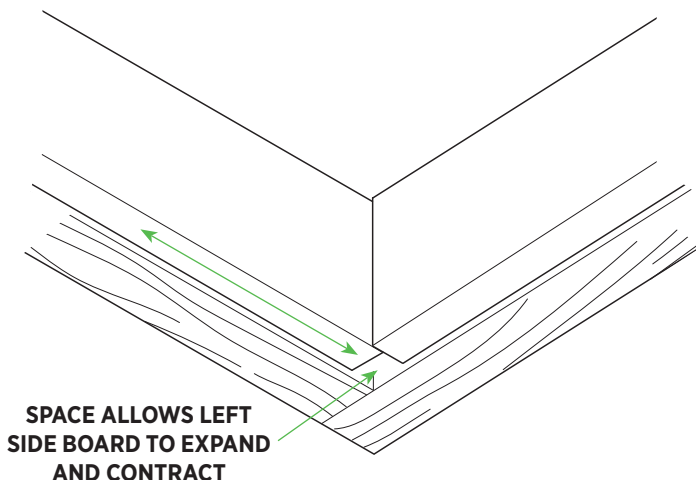

HIDDEN EXPANSION TECHNIQUE

PVC Trim

SPANNED APPLICATIONS / CEILINGS AND SOFFITS

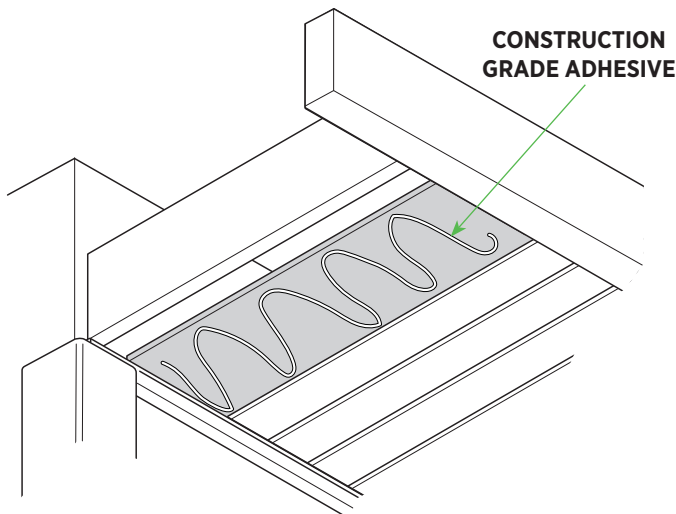
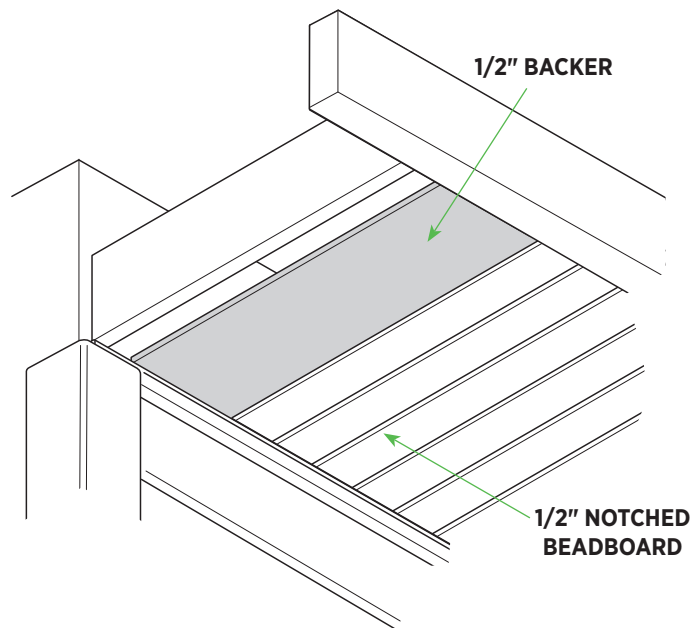
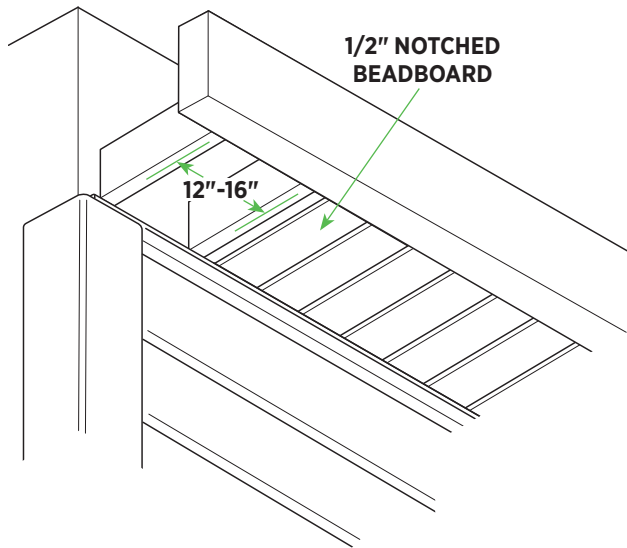

Spanned Applications

Ply Geadbead Board and Sheets are ideal for fascias, soffits, ceilings and other spanned applications. They cannot be used for load-bearing applications.

Note: A solid substrate must be installed on open rafter fascia application (use steps below).

Ceilings and Soffit

Before installing, review local building codes and regulations.

- 1/2" Notched Beadboard installed in ceiling areas should always cross ceiling joist spaced at 12" or 16" on center. Construction grade polyurethane adhesive provides additional support in hot climates. 1/2" Notched Beadboard must be painted to reduce dirt accumulation, due to the milling process required to form the beads.
- For spans greater than 16" on center, use a minimum 1/2" backer such as plywood or OSB with construction grade adhesive. Fasten board a minimum of every 16" to reduce or eliminate joist read through. Fasteners should hit joist or framing where possible.
- In hot climates, for spans greater than 12" on center, use 1/2" Moulding Beadboard or use a minimum 1/2" backer such as plywood or OSB with construction grade adhesive. Fasten Beadboard a minimum of every 8" to reduce or eliminate joist read through. Fasteners should hit joist or framing where possible.
- If temperature is 40°F or below at time of installation, do not span more than 12".

PVC Trim

FILLING NAIL HOLES / PAINTING

Filling Nail Holes

Use sealant designed to work with cellular PVC products. Once the product has set up, you may have to sand the area to achieve a finished appearance. If painting, caulk or

glue designed for use with cellular PVC is sufficient.

- Do not use caulks containing silicone.
- Avoid “stick” type nail “putty” that may contain wax.

Painting

Ply Gem Trim and Mouldings do not require paint for protection (with the exception of 1/2" Notched Beadboard). But because they don't absorb moisture like wood, they hold paint much better than wood. Be sure to use 100% acrylic latex paint formulated for vinyl products and follow the paint manufacturer's instructions.

- Apply a 100% acrylic latex paint with an Light Reflecting Value (LRV) of 55 or higher. Generally, the higher the LRV, the lighter the color.
- When painting a darker color with an LRV less than 55, use industry-proven finishes such as Sherwin-Williams® VinylSafe™ paints. They're available in a wide range of colors and designed to protect PVC trim from heat distortion.

- As with any surface to be painted, the trim must be clean, dry and free of chalk, grease, oil, dirt, mold or mildew. To ensure good adhesion, scuff sand with 100-120 grit sandpaper or Scotch-Brite® Scrub Sponge and remove dust from the surface before you paint.
- Verify whether the paint manufacturer requires primer. Priming may not be necessary.
- For the highest quality finished appearance, use an airless sprayer or compressor/paint gun system.
- You can also use a roller or brush – a roller produces a more consistent appearance.
- If the trim is to be pre-finished before installation, follow the manufacturer's suggested curing time before painting.

Ply Gem accepts no liability for type of paint used or the results of its use.

PVC Trim

USING A FIELD HEATING SOURCE



Bending PVC trim*

<https://deephow.ai/p/ZnRiV2k6PSxDEZqMYz3A>

Ply Gem cellular PVC trim can be heated and shaped to form curves using heat blankets, convection ovens, strip heaters, turbo heaters or radiant heaters*. Heat guns can be used to bend small areas where appearance isn't critical. For best results, do not bend woodgrain trim or trim that is more than 6" wide.

- To ensure uniformity and avoid discoloration, heat both sides of the material simultaneously — gradually increasing the temperature.
- Heating time is about 3 minutes for each 1/4" thickness of material. When the trim's shape is irregular or the heat is not uniform, heating times may be longer.
- Apply the heat evenly until the trim becomes flexible and easy to form.
- Always wear protective gloves. Hot PVC can produce severe burns.



Note: The use of a form/jig is recommended, PVC trim can cool quicker and harden before application of the product. By using a jig, clamping, and letting the product cool will give more working time especially on two story or multi-family applications.

If you prefer not to heat bend trim boards, 4 x 8 sheets can be used to create arches and other shapes.

Note: If bending a sealed edged product, cut away 1/8"-1/4" of the sealed edge to prevent wrinkling of the product.

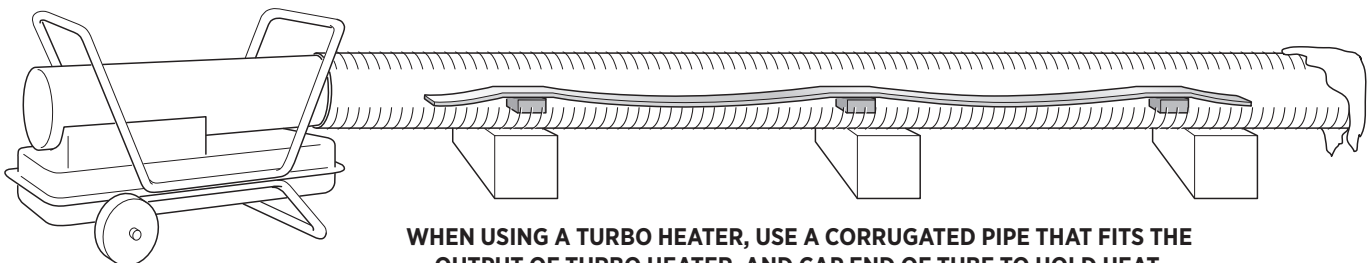

WHEN USING A TURBO HEATER, USE A CORRUGATED PIPE THAT FITS THE OUTPUT OF TURBO HEATER, AND CAP END OF TUBE TO HOLD HEAT.

*Heatcon, Inc. in Seattle is an industry proven supplier of heat bending blankets. Call 206-575-0815.

Heat Bending

USING A HEAT BLANKET

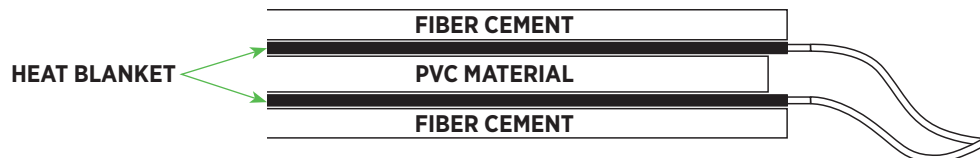
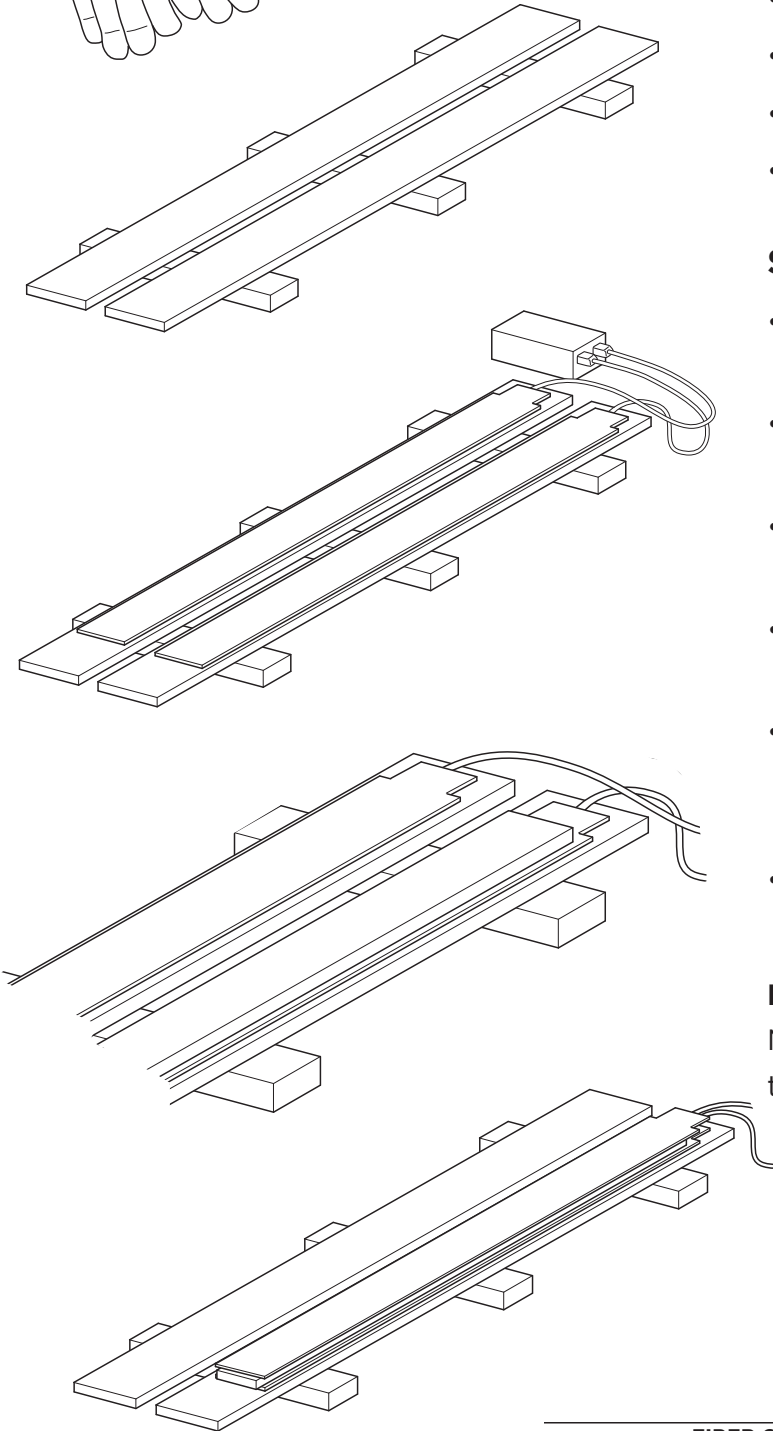

Heat Bending Using a Heat Blanket

Suggested supplies and materials:

- Template of radius to form.
- Heat resistant gloves.
- Heat forming kit.
- 8-10' sections of fiber cement siding.
- Wood blocks (to raise cement boards).

Suggested Procedure

- Place the cement boards on wooden blocks to protect work table from heat damage.
- Lay a heat blanket on each of the cement boards.
- Place the PVC material to be heated on the heat blankets.
- Lay the second heat blanket over the material.
- Lay a piece of cement board on top of the blanket. Be sure the PVC material doesn't shift.
- Follow equipment manufacturer's instructions to heat PVC to pliable stage.

Note: Make sure that the heat blankets DO NOT touch each other to prevent damage to the heating blankets.

PVC Trim

HEAT BENDING USING A JIG

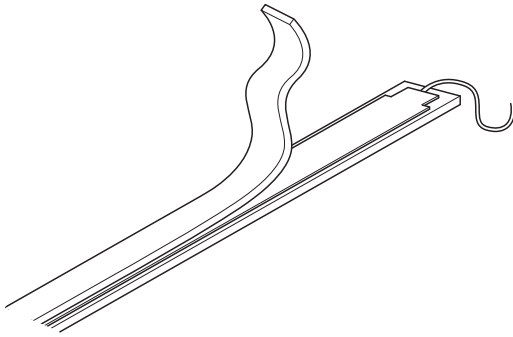

- Whether using heat blanket or other heating method, PVC material should feel like cooked spaghetti. If not, heat and test in two minute increments.
- Clamp one end of the softened material along the jig.

Note: If material wrinkles or isn't pliable enough to form, immediately straighten material and reheat.

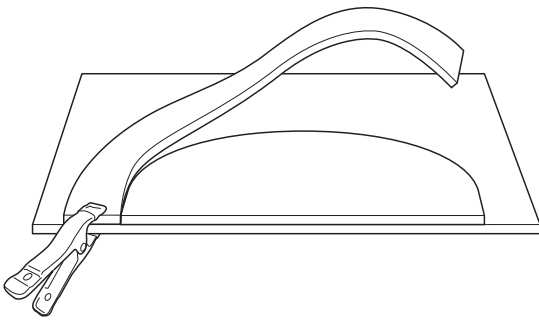

- Work PVC around jig.
- Clamp other end.
- Gently apply pressure by running gloved hands over PVC as it cools, or use a scrap piece of PVC and continue to apply pressure to smooth out the material while cooling.
- After PVC cools, remove clamps and install.

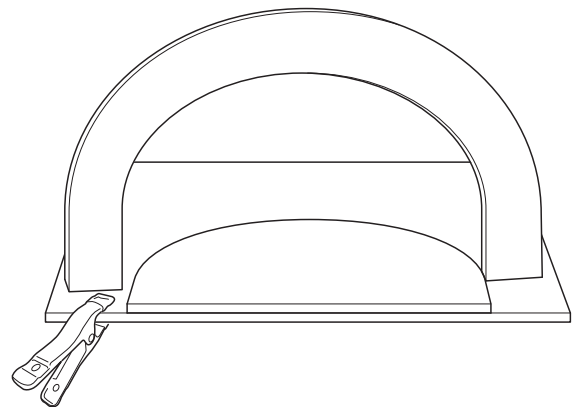
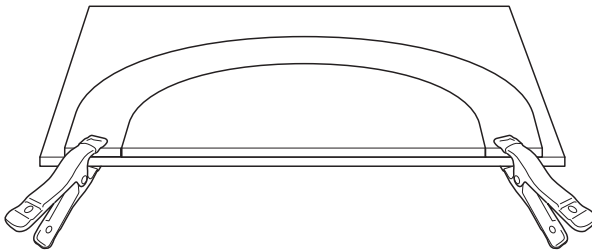

PVC Trim

NON-NOTCHED AND NOTCHED OUTSIDE CORNERS

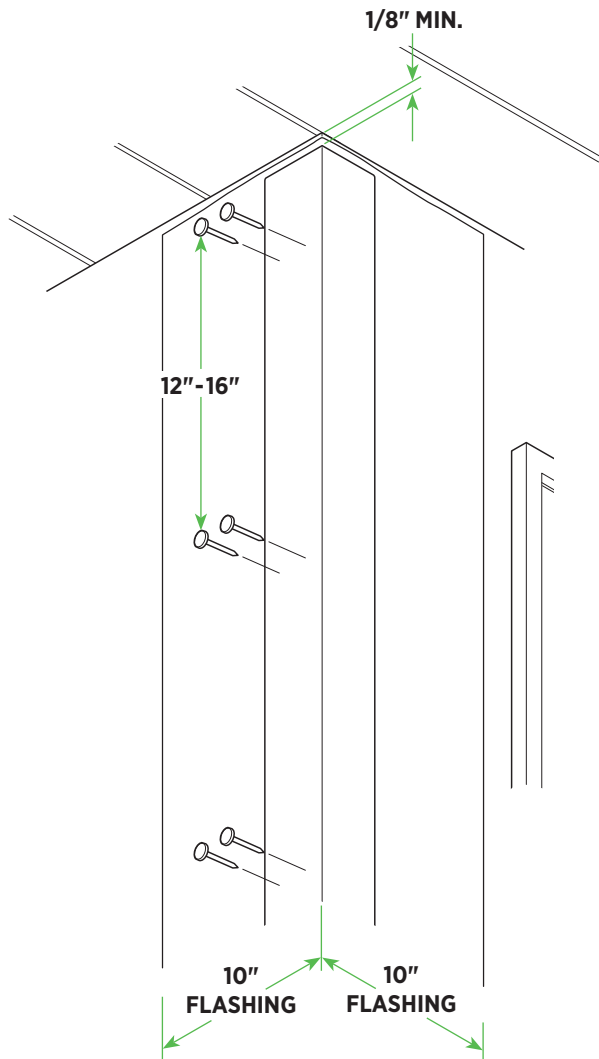

Note: A weather-resistive barrier must be applied before PVC trim is installed.

- Bend a 20" piece of trim coil 90° so you have two 10-inch-wide legs to flash the corners. Cover the entire height lapping the upper piece over the lower piece.
- Place the top of the one-piece corner at least 1/8" from the underside of the eave to allow for expansion. For longer lengths allow 1/4" gap from the eave for every 18' of corner. For vinyl siding, leave the bottom of the corner 3/4" below the starter strip.
- Make sure the post is straight and true before nailing. Do not nail through the J-notch opening.
- All fasteners should be 12"-16" max.

PVC Trim

FLANGED ONE PIECE OUTSIDE CORNERS

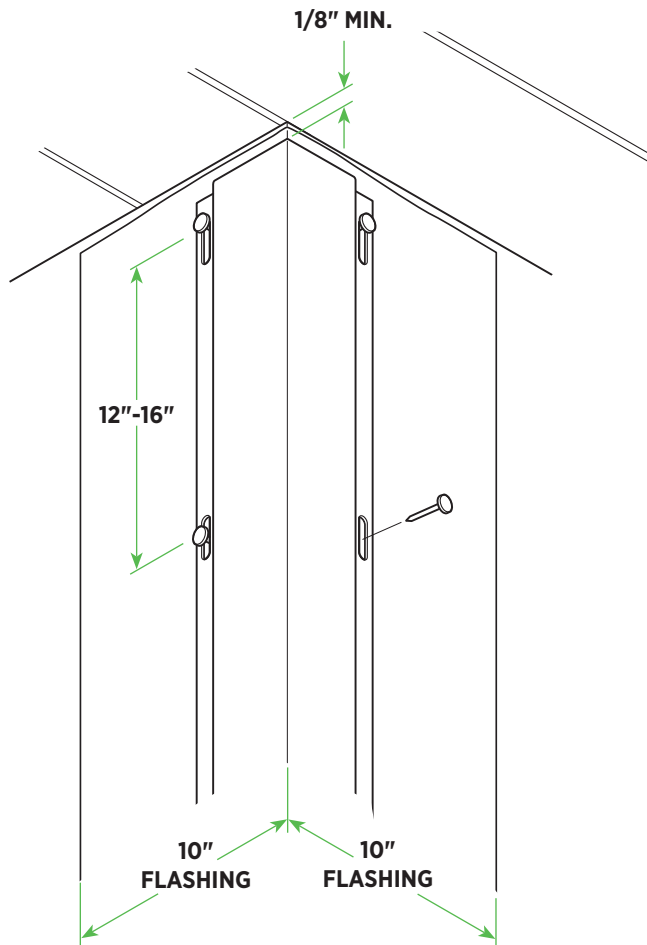

Note: These options eliminate the need for exposed fasteners. There are two flanged one piece corner options. One has a solid flange that can be used for any siding type. The second option is not notched and has a flexible hinged nail hem.

To install one-piece corners with attached nail hem flanges:

- Install 20" corner flashing.
- Fasteners must be noncorrosive, at least 2-1/2" long, with at least 5/16" diameter head and 1/8" diameter shaft.
- DO NOT fasten tight. Leave 1/16" between the fastener head and nail flange to allow for expansion and contraction.
- Position the uppermost screw at the top of the nail slot.
- All remaining fasteners must be positioned in the middle of nail slots.
- Install fasteners every 12" to 16".

PVC Trim

FLASHING WINDOW/CORNERS FOR NON-INSULATED VINYL SIDING

Field Forming Flashing for J-notched PVC

Application of J-pocketed PVC and any siding require these application steps be followed:

1. Bend and install the L-flashing.
2. Install the siding.
3. Install the window trim and corners.

These application steps are very important especially with short pieces of siding.

Window Applications

- For the bottom, cut and bend L-shaped flashing measuring 3/4" x 6" that extends beyond the window equal to the width of the trim. Measure the distance from the inside of the J-trim to the notch and fasten the flashing that distance below the window. Keep nails a minimum of 2-1/2" from the opening.

Note: If windows are being installed with the PVC trim follow the window manufacturer's specifications on how to flash windows.

- For the sides, create two similar flashings the full length of the trimmed dimension of the window. Nail each flashing the same distance from the window as determined previously. Cut the 3/4" "L" from the bottom flashing so the side flashings pass over the bottom flashing.
- Measure, cut and bend a "J-shaped" top trim flashing long enough to overlap the side trim by 6' on each side. Cut along the back of the top "J" shape flashing so the "J" can bend down over the side "J" leg.
- Install the siding.
- Fasten the trim in place. Do not nail through the J-notch opening.

Note: When using vinyl siding, this application should never require additional caulk.

Tip: if you use coil stock matching the siding color the trim can be repainted and the interior will always match the siding color.

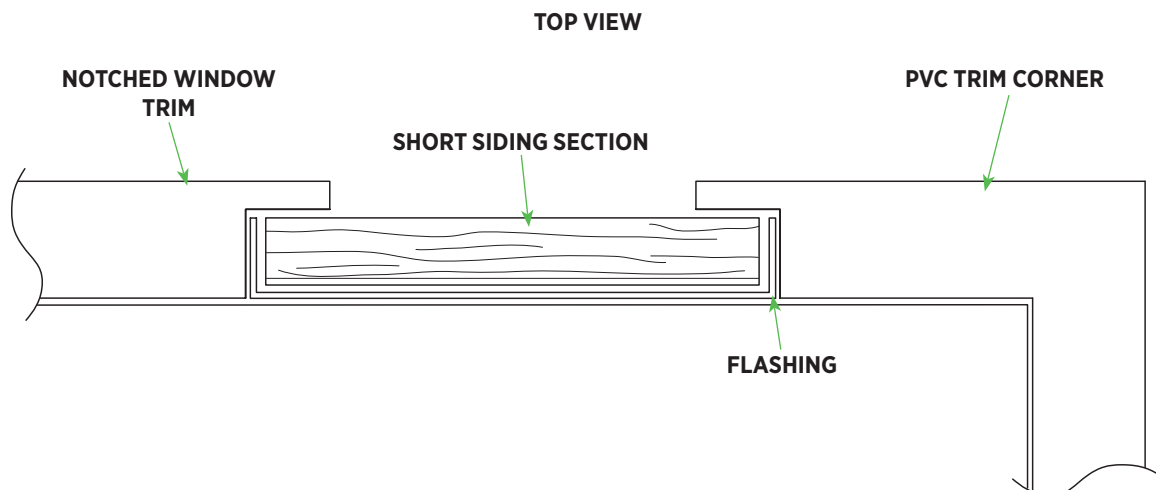

PVC Trim

WINDOWS/CORNERS WITH INSULATED VINYL SIDING

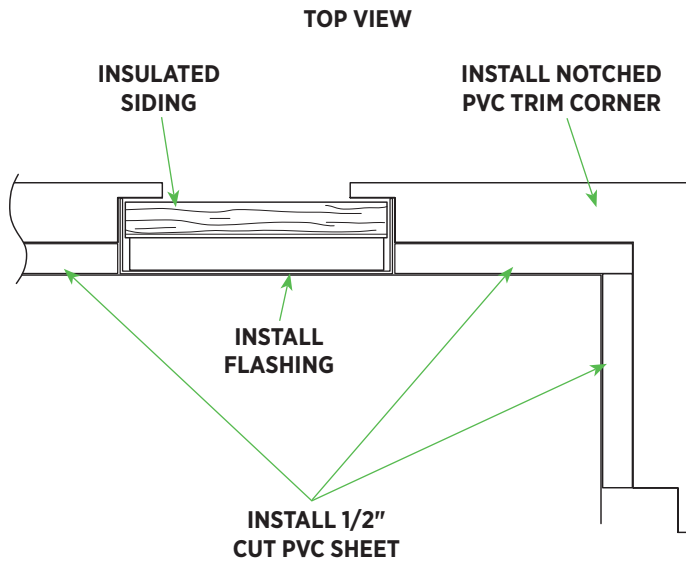

Because insulated siding is approximately 1-1/4" thick, you'll need to pack out trim boards to create a pocket for the siding.

- For corner boards and window trim, measure the distance from the inside of the PVC trim piece to the notch then rip enough material from sheets of 1/2" cellular PVC to match one side of the PVC trim piece.
- Fasten the ripped 1/2" thick sections onto the PVC trim piece.
- Follow the L-flashing steps on the previous page, but for insulated siding one leg will be 1-1/4". Use coil stock to create two L-shaped flashings measuring 1-1/4" x 6" x full height of corner.

Tip: if you use coil stock matching the siding color the trim can be repainted and the interior will always match the siding color.

- Position each flashing against the spacers that were applied at the corner.
- Install the siding.
- Apply a continuous bead of sealant (allow curing time before installing) along the entire perimeter of the spacer boards about 1/2" from the edge.
- Fasten the corner in place. **DO NOT NAIL** through the J-notch opening.

Note: When using vinyl siding, this application should never require additional caulk.

PVC Trim

WINDOW AND DOOR TRIM—WINDOW FLANGES WITH SCREW HEADS

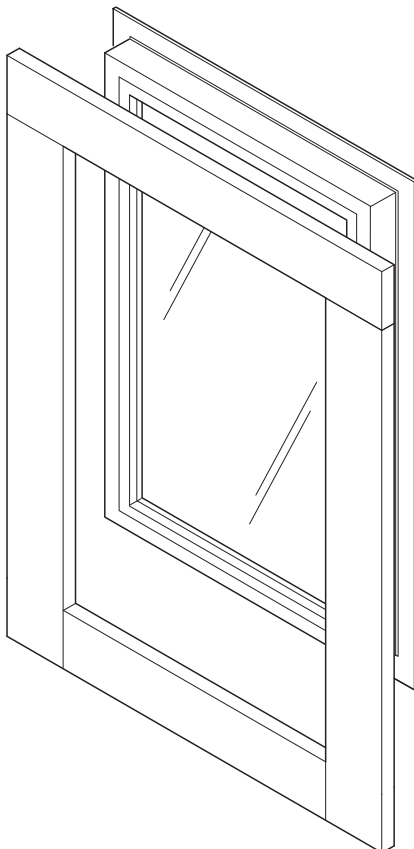
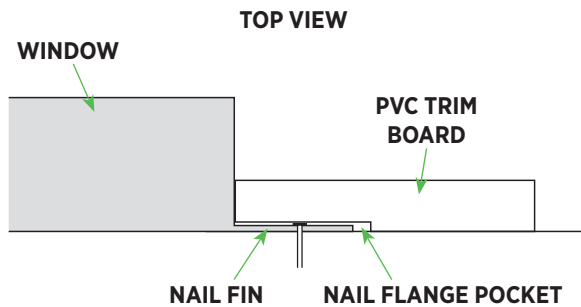
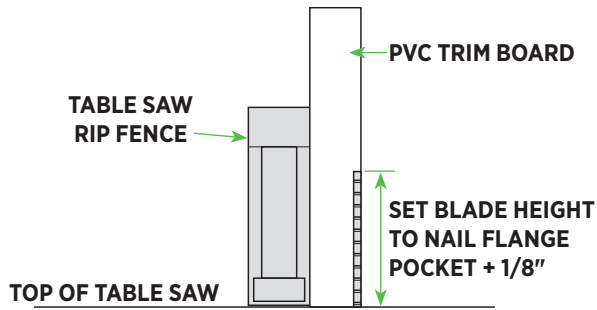

Window and Door Trim

To create a nailing flange pocket with relief cut:

- Measure the width of the nail fin where you plan to apply trim.
- Set the blade depth of table saw approximately 1/8" higher than the width of the nail fin.
- Set the table saw fence so you are cutting away only the thickness of the saw blade from the trim board.
- Make one cut from the back side of the trim board on table saw.
- Check to be sure the trim board will lay flat against the wall and that all joints are tight prior to fastening. If the boards do not lay flat against the wall or the joints are not tight, repeat above steps.

PVC Trim

PICTURE FRAMING WINDOWS

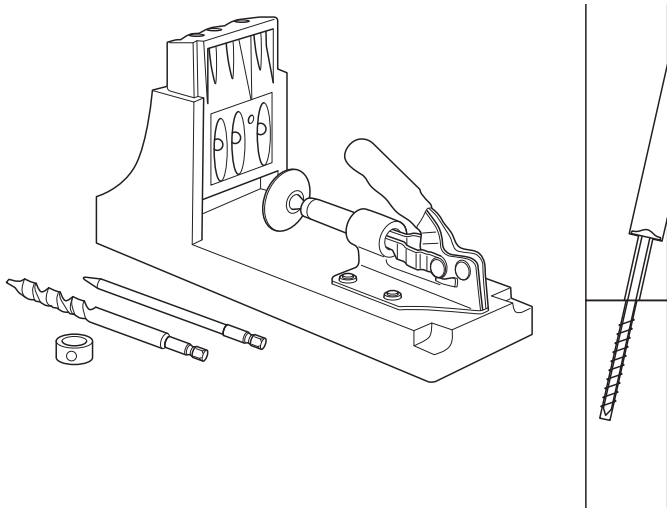

Window and Door Tip: You may wish to consider the use a Kreg jig to create a better joint.

Note: PVC trim is intended to be aesthetic and not part of the water resistant system.

- Flash window.
- Assemble PVC window frame before installing around window. Joints should be glued and screwed together.

Tip: Use pocket screws where possible. Use only weather-resistant screws.

- Measure the width and height of the window and add 1/8" to both measurements. This will leave 1/16" space around the window to allow for expansion and contraction.
- Attach frame to wall using industry-proven fasteners.

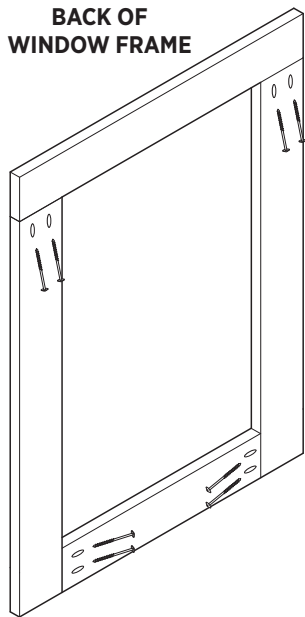

BACK OF WINDOW FRAME

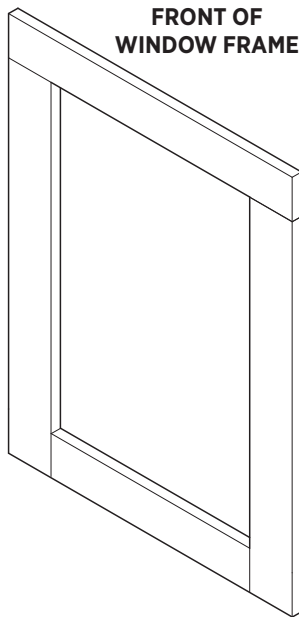

FRONT OF WINDOW FRAME

Adding Crown and Sill/Sub Nose

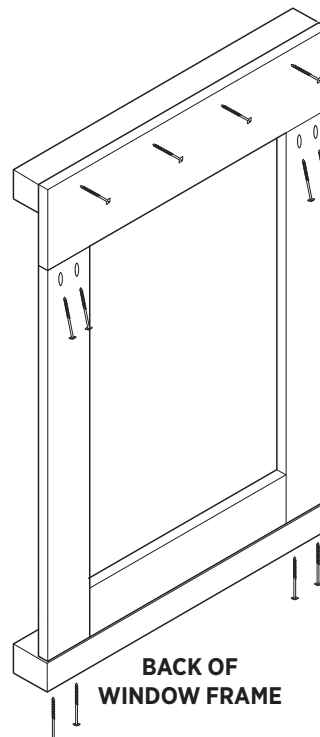

BACK OF WINDOW FRAME

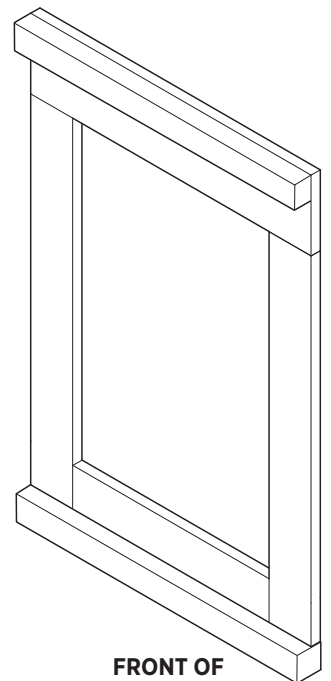

FRONT OF WINDOW FRAME

PVC Trim

PICTURE FRAMING WINDOWS – SPECIAL APPLICATIONS

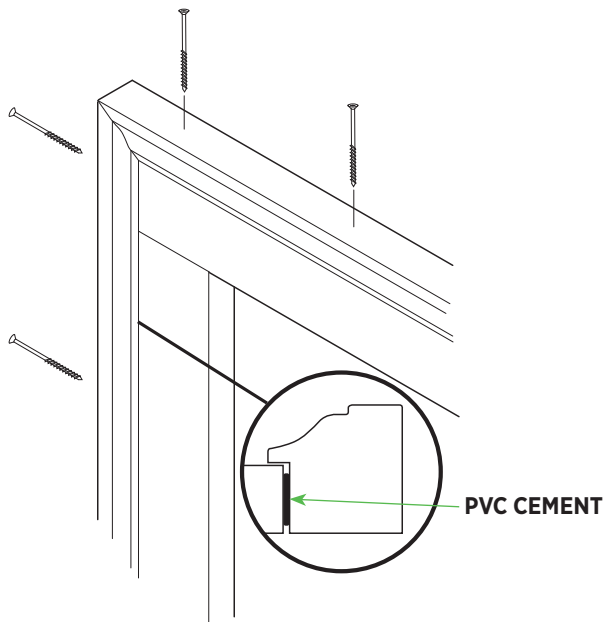

Installing Inside Backband

- Run a bead of PVC cement along side edge of window trim.
- Install backband and fasten using the industry-proven fasteners.

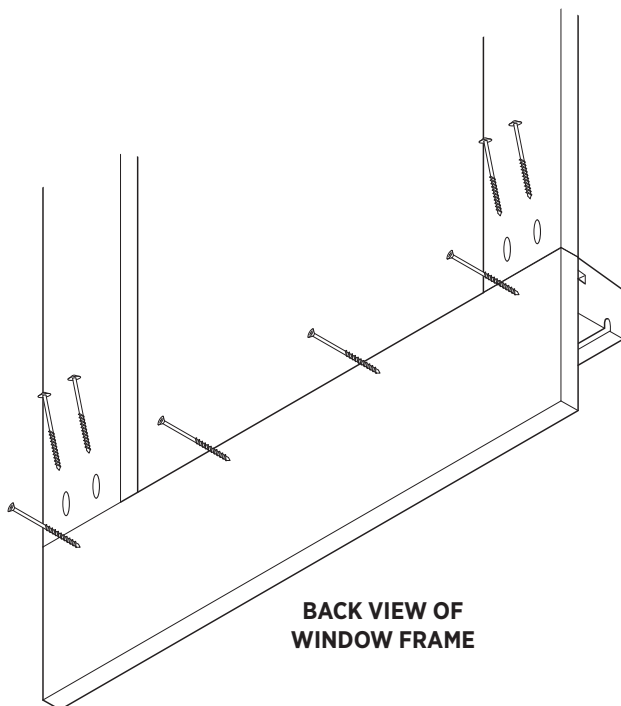

Installing an Apron

- Run a bead of PVC cement on apron where sill will be placed.
- Fasten using industry-proven fasteners.
- Use a Kreg jig for attaching these pieces.

PVC Trim

PICTURE FRAMING WINDOWS – SPECIAL APPLICATIONS

METHODS FOR ASSEMBLING CONCEAL TRIM

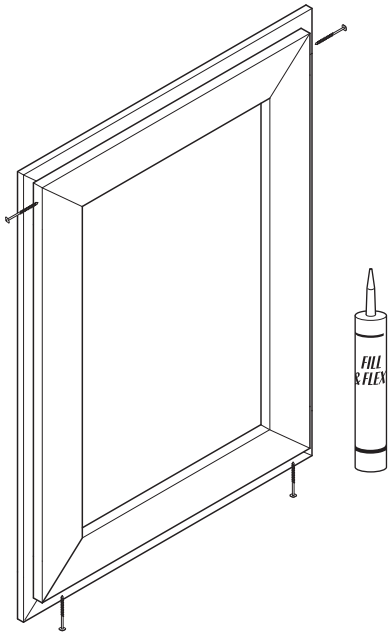

SCREWS/MITERED CORNERS

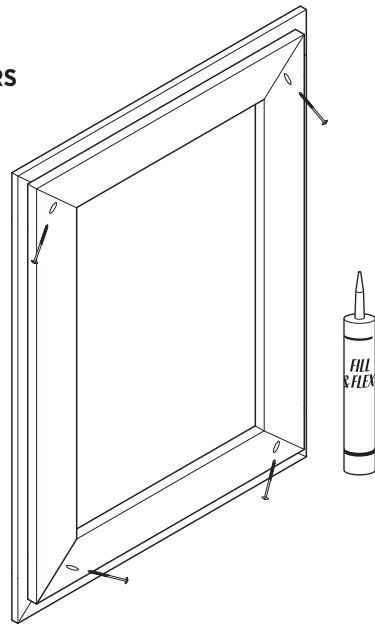

POCKET SCREWS/MITERED CORNERS

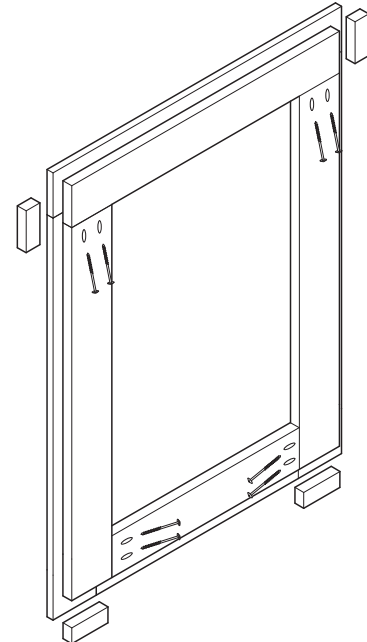

POCKET SCREWS/SQUARE CORNERS

Conceal Window Trim Assembly

- Make sure to leave 1/16" space on all four sides of the window for expansion and contraction of the trim.
- Assemble trim frames before installing on wall.
- For aesthetic purposes, use adhesive on all miters and squared joints around windows and doors.
- When square cutting joints, end pieces to create a continuous channel.
- When securing frame to the wall, fasteners must not penetrate through the siding pocket.
- Install head flashing inside the pocket of the header trim.

PVC Trim

SKIRT OR FRIEZE BOARDS WITH SIDING

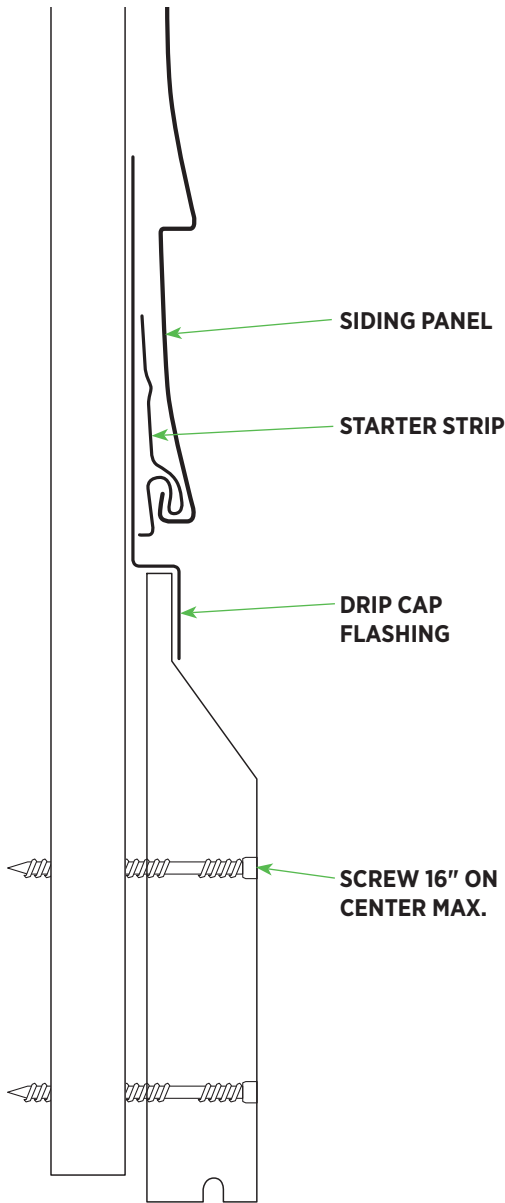

Skirt or frieze boards can make an attractive band at the bottom of walls with the application of any siding panels. Use a flat PVC trim of any size as a frieze option.

- Install skirt/frieze board where needed. Attach no more than every 16" on center. Use the board width chart for vertical fastening requirements based on width of board being used.
- Install a drip cap flashing with a minimum of 4" leg up the wall (and integrated into the weather-resistive barrier). Form the drip cap so it covers the front face of the skirt or frieze board as shown.
- Install the required starter strip onto the drip cap face. If the starter strip is a J-Channel, leave a 1/8" gap. If the starter accessory is a starter strip leave a 3/8" gap.
- Install the siding onto the starter strip. If a drip cap is used, it should be attached to skirt board with recommended adhesive.

Note: If using fiber cement siding, follow that manufacturer's requirements.

PVC Trim

POST WRAPS

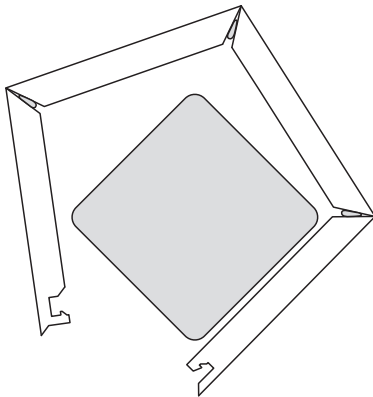
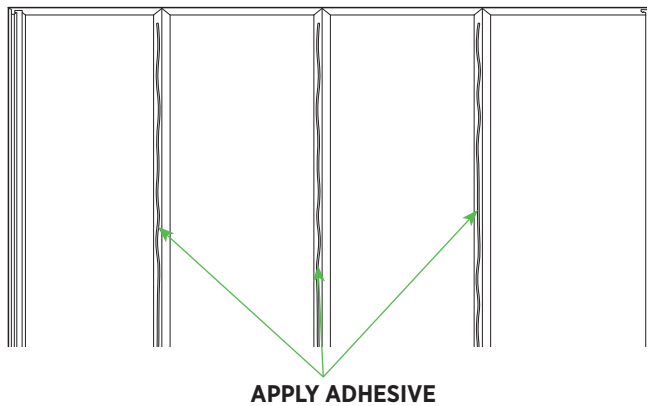
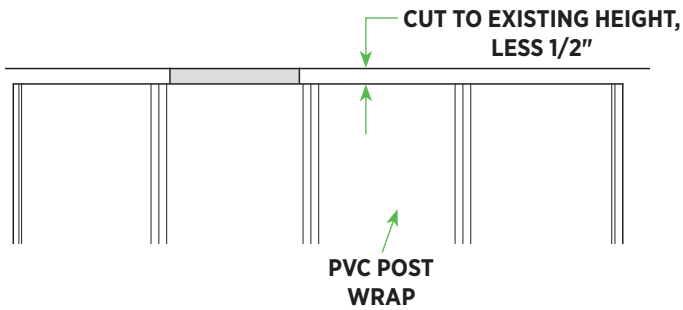

TOP VIEW

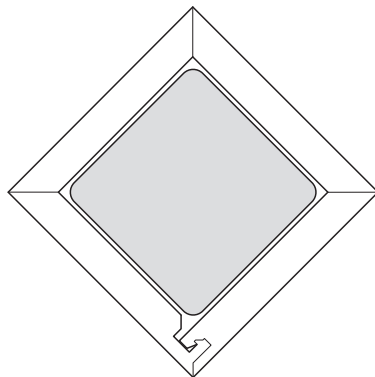

TOP VIEW

The four-piece design snaps together, requires minimal adhesive and easily fits around existing posts. These post wraps come with a protective peel-away film. Remove this film and corner tape before fastening, painting or adding molding.

- Measure the installation site floor to ceiling, then cut the four pieces 1/2" shorter than the full height.
- Apply a bead of adhesive to the length of one side of each of the three inside angled folding surfaces.
- Snap the four pieces together around the post.
- Shim the assembled cover 1/4" off the floor and fasten each section to the post using two fasteners within 3" of the top and bottom of the assembly.
- Apply accents and mouldings as desired for added appeal.

Note: Ply Gem pre-made mould trim kits can be used. The use of these kits will allow the installer to piece together each piece of decorative trim that is pre-notched and mitered with attachment biscuits in the pack. Glue the mouldings and trim nail to secure.

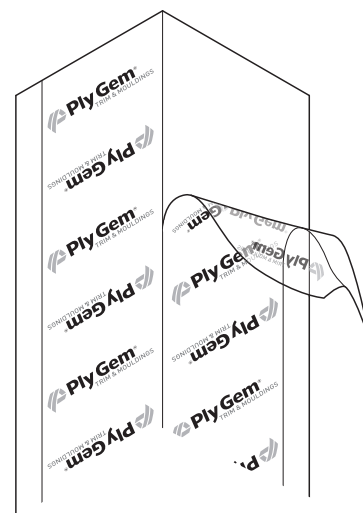

PVC Trim

GARAGE DOOR TRIM

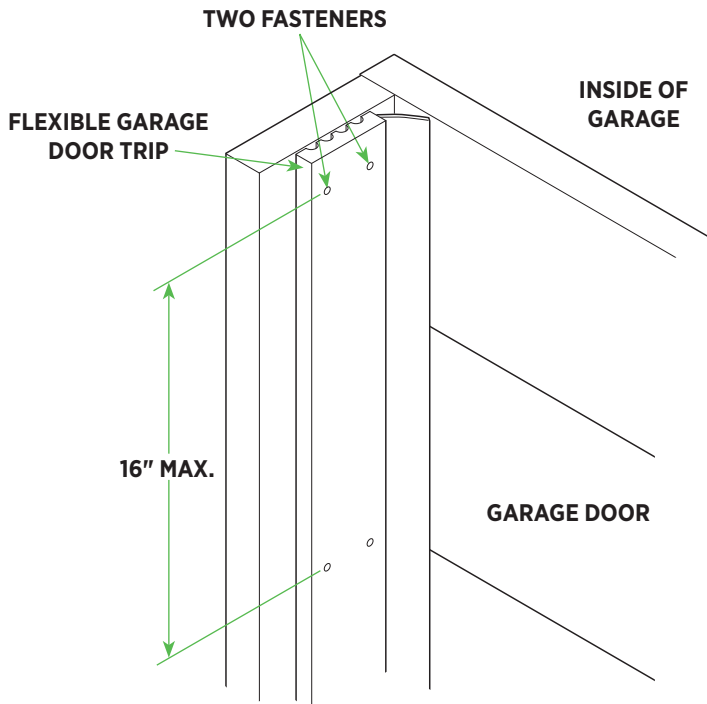

Note: Apply 2 fasteners per width of product, fastening no more than 16" vertically as well.

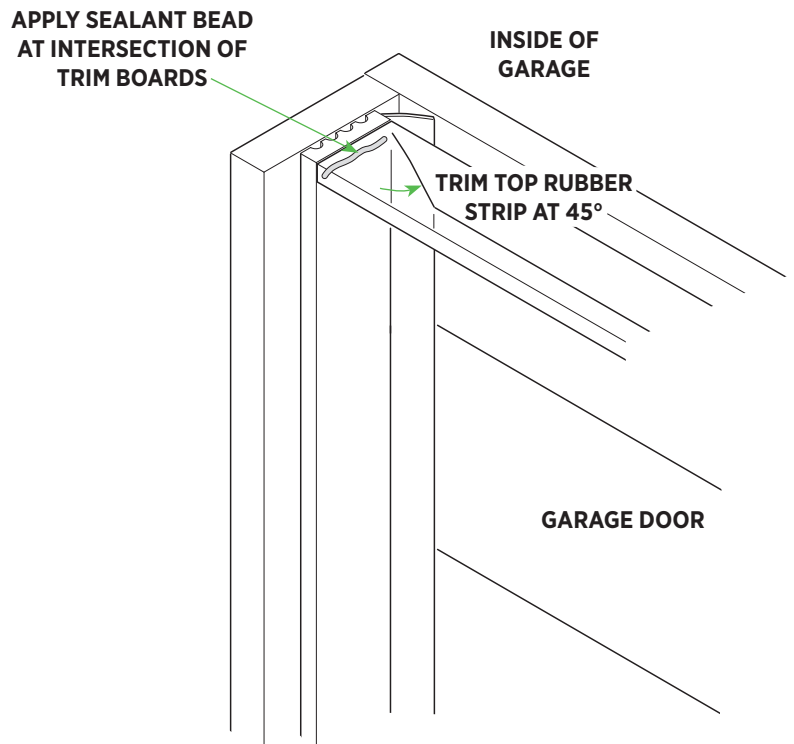

Industry Terminology

GLOSSARY

Actual Dimensions — The exact measurement of a piece of trim, moulding, or trim board.

Band Board — A decorative piece of horizontal trim placed between two floors along the rim joist.

Beadboard — A flat panel or sheet good routed with a beaded detail at regular intervals. Typically used for wainscoting and porch ceiling applications.

Beaded — A narrow, half-round molding at the base of a lap siding panel.

Casing — Molding of various widths used to trim door and window openings at the jambs; also referred to as lineal, window, or door surround.

Countersink — To secure a fastener to sit flush with or below the surface of the surrounding material.

Course — A row of siding panels running the width of the wall.

Jig — Material in the radius needed; used to shape PVC building products.

Dormer — A gabled extension built out from a sloping roof to accommodate a vertical window.

Drip Cap — A horizontal flashing placed over exterior door or window frames to divert rainwater.

Eave — The overhang of a pitched roof at the bottom edge, usually consisting of a fascia board, a soffit for a closed cornice, and appropriate moldings.

Expansion — Commonly refers to building products expanding as outside temperature changes.

Expansion and Contraction — Commonly refers to construction material expanding when heated up or contracting when cooled, especially as outside temperature changes.

Expansion Joint — An assembly designed to safely absorb the heat-induced expansion and contraction of various construction materials.

Exposure — The width of the exposed face of each panel of siding; also referred to as reveal.

Face — The side of the siding, trim, or soffit that is exposed to view after the product has been installed.

Fascia — A flat, horizontal band that covers the rafter tails and runs along the bottom edge of the roof line.

Fastener — Generic term for nails, screws, bolts, and metal hardware.

Flashing — A thin, impervious material, usually metal, placed around openings to prevent water penetration or to direct the flow of water over the cladding.

Frieze — The horizontal trim board connecting the top of the siding with the soffit.

Furring/Furring Strip — Long, thin strips of wood or other materials used to build out the fastening surface of a wall; commonly used to correct imperfections in wall surfaces, to establish a rain screen, or to re-establish a structural fastening surface on the exterior of nonstructural products such as foam insulation.

Gable — The triangle formed on the side or the front of a building by a sloping roof.

Industry Terminology

GLOSSARY

Hot-dip Galvanized — The process of dipping metal into molten zinc to apply a protective coating that prevents corrosion; hot-dipped galvanized iron and steel are corrosion resistant.

IBC — International Building Code

IRC — International Residential Code

Light Reflecting Value (LRV) — A measure of the amount of light that is reflected off a surface. Generally, the higher the LRV, the lighter the color.

Lineal — Molding of various widths used to trim door and window openings at the jambs; also referred to as casing, window, or door surround.

Mechanically Fasten — The joining of two or more materials using fasteners such as nails, or screws.

Miter Cut — A beveled cut, usually 45°, made at the end of a piece of molding or board that is used to form a mitered joint.

Nominal Dimensions — The identifying dimensions of a piece of lumber; for example, a 2 x 4 is the name for a rough-cut piece of about 2 in. x 4 in.; nominal dimensions are usually larger than actual dimensions.

Pneumatic Nailer — A nail gun or nailer is a type of tool used to drive nails into wood or other material. It is usually driven by compressed air.

On Center (O.C.) — A measurement of the distance between the centers of two repeating members in a structure, usually studs.

OSB — Oriented Strand Board.

Panel Projection — The distance that the bottom edge of the siding projects from the wall.

Profile — The contour or outline of a trim piece as viewed from the side.

PVC Trim — Trim stock made of polyvinyl chloride.

Rake — Trim members of a gable roof that run parallel to the roof slope from the eave to the ridge.

Recommended Span — The distance a building material can safely traverse without being supported underneath.

Rigid Sheathing — Plywood, OSB, or foam sheathing.

Rim Joist — The board that the rest of the joists are nailed to. It runs the entire perimeter of the house.

Rip Cut — A cut made lengthwise on a piece of siding or trim.

Scarf Joint — A scarf joint (also known as a scarph joint) is a method of joining two members end to end. The scarf joint is used when the material being joined is not available in the length required.

Sheathing — Sheets of plywood, exterior gypsum board, or other material nailed to the outside face of studs as a base for exterior siding.

Shim — A building material, usually wood used to even a surface.

Skirtboard — Treated lumber or PVC trim board installed horizontally; used as a transition from foundation to siding or as a starter strip.

Industry Terminology

GLOSSARY

Soffit — The underside of an overhanging eave.

Square — Unit of measure for siding; equal to 100 square feet of exposure (e.g. a 10-ft. by 10-ft. wall section = 100 square feet = 1 Square).

Span — The distance between supports.

Starter Strip — An accessory used to engage the locking leg of the first course of siding.

Structural Member — A support that is a constituent part of any structure or building.

Structural Sheathing — The layer of boards, wood or fiber materials applied to the outer studs, joists, and rafters of a building to strengthen the structure and serve as a base for an exterior cladding.

Substrate — A layer of material applied over the studs at the exterior walls of a building.

Weathering — Photochemical degradation of the surface of a material caused by the combination of sunlight (UV radiation), water, and abrasion by wind-blown sand, dirt, or other particulates. In wood and other building materials, weathering is characterized by color change.

Excessive weathering of unfinished wood can cause checking, cracking, and splintering.

Weather-Resistive Barrier — A building membrane that protects building materials from exterior wind and water penetration.

Note: The actual measurements are the final size. If your project calls for precise measurements, be sure to check with manufacturer for guidance:

Nominal Size	Actual Size
1×2	3/4" × 1-1/2"
1×3	3/4" × 2-1/2"
1×4	3/4" × 3-1/2"
1×6	3/4" × 5-1/2"
1×8	3/4" × 7-1/4"
1×10	3/4" × 9-1/4"
1×12	3/4" × 11-1/4"
2×2	1-1/2" × 1-1/2"
2×3	1-1/2" × 2-1/2"
2×4	1-1/2" × 3-1/2"
2×6	1-1/2" × 5-1/2"
2×8	1-1/2" × 7-1/4"
2×10	1-1/2" × 9-1/4"
2×12	1-1/2" × 11-1/4"
4×4	3-1/2" × 3-1/2"
4×6	3-1/2" × 5-1/2"
6×6	5-1/2" × 5-1/2"

Crafted to Deliver. Captivating Curb Appeal.

Easy to install to highlight your build's best features,
Ply Gem Trim & Mouldings' low-maintenance
product will turn a glance into a gaze.



5020 WESTON PKWY. | CARY, NC 27513 | 888-9PLYGEM | PLYGEMTRIM.COM

We reserve the right to alter, modify or delete items from time to time without notice. Contact your distributor or sales representative for actual product samples. Ply Gem, Ply Gem Trim and Mouldings, BuildReady, DesignReady, and PlyPak are trademarks of Cornerstone Building Brands, Inc. and/or its subsidiaries.

© 2023 Ply Gem, part of **Cornerstone Building Brands**, Inc. ALL RIGHTS RESERVED. All products made in the U.S.A. 6402136641101/ReC/MS/CG/0623

[< PREVIOUS PAGE](#) | [MANUAL COVER](#) | [MANUAL CONTENTS >](#)



PART OF THE CORNERSTONE BUILDING BRANDS FAMILY | SIDING + ACCESSORIES | WINDOWS + DOORS | STONE VENEER | TRIM + MOULDINGS | FENCE + RAILING