

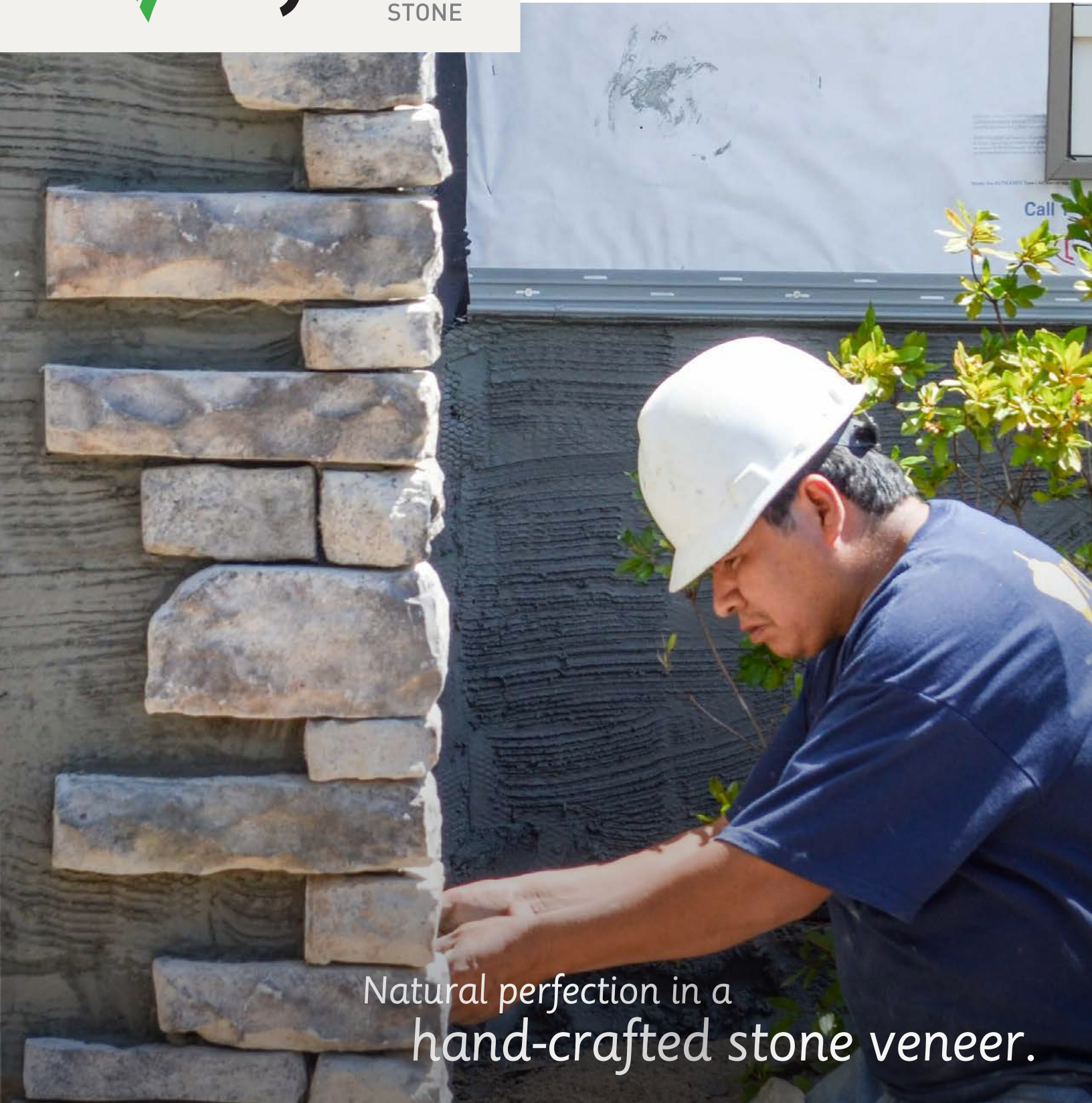

INSTALLATION GUIDE



Natural perfection in a
hand-crafted stone veneer.

Ply Gem is a 70-year leader in pioneering performance home exteriors,
with a superior warranty for exactly the home you want for decades to come.



SHADE MOUNTAIN COBBLESTONE

Getting your project started



Thank you for considering Ply Gem Stone for your next building project. It is important to choose a manufacturer that has been evaluated for quality by a third party, as many have not submitted their stone veneer for testing. Our plants and processes have been audited to prove they are the highest quality, as verified in IAPMO ER #337, issued January 2013. This Installation Guide provides step-by-step information that will be beneficial to a successful stone veneer installation that will be admired for years to come. Please carefully review the guidelines for estimating, preparing, installing, and caring for your new stone veneer application. Reading through this entire guide prior to ordering and installing your stone veneer will provide a quality, satisfying experience. If you have any questions, please contact your Ply Gem Stone representative.



SHADE MOUNTAIN
SHADOW LEDGESTONE

Estimating your stone project

Step 1: Determine how many linear feet (running feet) of corners you need.

Step 2: Determine square footage of flat stone you need by multiplying the width by height, then subtracting the square footage of any openings, such as doors and windows. If using corner stones, take half the number from Step 1 and subtract it from your square footage to get the approximate total square feet needed.

Step 3: Because of inherent waste during installation, we suggest ordering 10% more than the total square feet (Step 2) and linear feet (Step 1) to achieve your total stone estimate.

Step 4: Using your estimates (Steps 1 through 3), determine the number of boxes you will need to complete the project. Using a standard 1/2 inch grout joint, flat stones are 10 square feet per box. If dry stacking, all flat stones are 8.5 square feet per box. All corner stones are 5 linear feet per box.

Step 5: If you need wire lath, divide the total square footage (Step 2) by 18 square feet (total sq. ft. of the wire lath) to get the number of sheets necessary.

Step 6: If you need a weather resistive barrier (WRB) for your installation, please consult your supplier to determine quantity needed.

Step 7: Determine the amount of mortar you need. Divide the total square footage (Step 2) by square feet for jointed stone and square feet for stacked stone. This will determine the total amount of pound bags necessary for the scratch coat, buttering the back of the stone before application, and grouting.

Installation Guide Instructions

(Please refer to diagrams on pages 6-13 for variations)

Required Tools:

- Wheelbarrow
- Hoe
- Safety glasses
- Hammer
- Margin trowel
- Tile nippers or hatchet
- Grout bag
- Pointing tool (or 1/2" wooden dowel with dull point)
- Whiskbroom or 3" paint brush
- Measuring device (such as large coffee can)
- Masonry rake

Optional Tools:

- Air-powered roofing nail gun
- 4' level
- Chop saw with masonry blade
- Notch-tooth trowel (to spread scratch coat)
- Wet saw

Step 1: Installing the Weather Resistive Barrier (WRB)

(if necessary)

A local Ply Gem Stone dealer can provide either or both the WRB and Rainscreen. Ply Gem Stone recommends that two separate layers of WRB are used in all exterior applications. One layer is recommended for interior use. The WRB must meet the requirements established by IBC Section 1405.10.1.1; IRC Section R703.2. The product should have an IAPMO Evaluation Report that shows how to install the product. The joints of the WRB should overlap by 4 inches.

Grade D paper with 60-minute rating or felt paper meeting ASTM D 226 Type I may be used as WRB.*

Some building codes require a rainscreen drainage plane system. Rainscreen must meet the requirements established by IBC Section 1405.10.1.1; IRC Section R703.2. The product should have an IAPMO Evaluation Report that shows how to install the product.

** Felt meeting ASTM 4869 or non-ASTM #15 felt is not recommended for use behind veneer.*

Step 2: Installing the Metal Lath (if necessary)

A local Ply Gem Stone dealer can provide a metal lath. For proper installation, lath should feel rough when rubbing down and smooth when rubbing up. Use galvanized fasteners to install the metal lath horizontally. It is very important to insert a fastener approximately every six inches vertically, and 16 inches horizontally to overlap the joints by approximately one inch. Where possible, insert fasteners into the framing studs.

In case of both inside and outside corners, the lath must be continuously wrapped 16 inches around each corner.

Lath is not necessary when applying scratch coat to a clean concrete surface. If the surface has any type of loose debris or particles come off the wall, lath must be utilized to get a good bond between concrete and the scratch coat. No chemicals should be on the surface that may interfere with bonding.

Note: If the metal lath flexes when pressed, insert more fasteners. The lath and lath attachments must be made of corrosion-resistant material.

Self-furred 2.5 lb. metal lath meeting IBC Section 2510.3 (ASTM C926 and ASTM C1063); IRC Section R703.6.1 For proprietary fasteners, shear and pull out capacities shall be justified to the satisfaction of the authority having jurisdiction (AHJ).

Step 3: Mixing the Mortar

Mix one part Type S mortar and two parts clean masonry sand with water and stir until the mixture holds a whipped consistency. After 30 minutes the mortar will begin to thicken, a little water may need to be mixed in. However, each time you add water, the mortar becomes weaker. To avoid weak mortar and waste, mix small batches. After 2 hours, discard mortar. Times will vary based on weather. For example, hotter days will set up mortar faster which gives less time to use it. Always follow mortar manufacturer instructions.

Premixed mortars may be used provided it meets the requirements of ASTM C 270 for Type S mortars and designed for use with manufactured stone veneers. Polymer modified premixed Type S mortar meeting ASTM C 270 is also acceptable. Half inch thick scratch coat of Type S mortar complying with ASTM C270, scored horizontally in accordance with IBC Section 2512.6.

Mortars must provide a minimum of 50 psi shear bond strength. Check with stone supplier if you have questions.

Note: Each time you add water, the mortar becomes weaker. To avoid weak mortar, mix small batches.

Step 4: Applying the Scratch Coat

Follow Step 3 to mix the mortar. Then, take a trowel and spread the whipped mixture thinly, making sure the lath is completely covered: Spread the mixture with a minimum of 1/2 inch thickness. Apply pressure to ensure a secure bond. The mortar should be scored horizontally with a notched trowel or scarifier to create the scratch coat when the mortar has become thumbprint-dry. Allow this to dry for at least 24 hours before applying stone.

Note: Installer must use judgment for curing time required based on weather conditions. Scratch coat must be firm and properly cured to ensure a secure bond. Avoid uncovering the metal lath.

Step 5: Mixing the Mortar for Stone Application

Follow Step 3.

Step 6: Wetting the Veneer

For all applications, the scratch coat and veneer must be moistened to reduce the initial rate of absorption. This can be done by spraying water onto the wall surface and back of veneer. Veneer can also be dipped into a container of water. The back of the veneer and the scratch coat surface should appear wet but should not have excess water on the surface. This is especially important in summer or hot weather conditions.

Step 7: Applying Mortar to the Stone

Make sure your hands are clean so you do not smear the face of the stone. Using a trowel, spread a thin layer of mortar on the back of the stone, then push and scrap the mortar into the surface to create proper bonding. This action is like buttering bread. Now add 3/4 inch of mortar to the middle of the stone. Taper it towards the edges (it will spread when applied) Ensure the entire back of the stone is covered.

Step 8: Shaping the Stone (if necessary)

If necessary, the stone's shape may be altered with a pair of tile trimmers, a hatchet, or a saw with a masonry blade prior to mortaring the back of the stone. Mark the desired shape before cutting. Buttering the altered end before installing will help the stone blend nicely and conceal trim marks. Always use proper protection when cutting veneer. Straight cuts can be made with a diamond or carbide saw blade. Rinse surface of the veneer after cutting to avoid staining from the dust. To help conceal cut or broken edges, cover them with mortar when grouting the veneer. Always use NIOSH approved safety glasses when cutting or chipping stones. Repeat or prolonged exposure to silica dust can be hazardous to exposed person's health. A respirator for dust is recommended when cutting stone veneer. The use of a wet saw versus a dry saw will lower the exposure to silica dust.

Step 9: Applying the Stone

Hands must be clean so face of stones aren't marked. Lay out 30 feet of the stone so that you can become familiar with the various colors and shapes of the product in which you are installing. Laying out the stone like it is on the wall will help you balance the size, shapes and colors.

Install the outside corners first by alternating the long and short sides. Then work the flat stones into the corners. Working from the top down helps avoid dripping mortar on previously installed stone when using a standard joint or an overgrout joint technique. For dry stacking, installing from the bottom up is easier.

Refer to Step 7 to apply mortar to the back of the stone. When mortar is applied, press the stone firmly into place on the prepared wall surface, squeezing the mortar out around all the edges. Use a gentle wiggling action while pressing the stone to ensure a good bond. Place grout into any gaps.



BUCKINGHAM FIELDSTONE

Note: Be careful not to bump the pieces after installing them, this will compromise the bond. If this happens, stones should be removed and reinstalled.

Windows, doors and edges of walls will require you to alter stone to fit the space available. The stone's shape may be altered with a pair of tile trimmers, a hatchet or saw with a masonry blade. Refer to Step 8 for detailed recommendations.

When applied, if the stone does not stay, the mortar is too dry and water must be mixed into the mortar. If stone slides, the mortar is too wet and mortar must be thickened. With either case, the mortar must be scraped off the stone and reapplied. Then the stone can be placed back on the wall.

Grouting of joints can be done as stone is laid or after it has all been installed. Grouting dry stack to ensure no scratch coat is exposed is easier as stone is being installed.

If excess mortar gets on face of the stone, allow it to dry SLIGHTLY prior to removing it. Then brush away powder. DO NOT REMOVE WHEN WET as this will cause staining. DO NOT ALLOW TO DRY OVERNIGHT.



AUTUMN FIELDSTONE, CUT COBBLESTONE AND SHADOW LEDGESTONE

Installing Stone with a Standard Joint Technique

The standard joint is achieved by laying each piece of veneer roughly 1/2 inch apart (two finger width). Corner and flat pieces should be installed from the top-down. Using a masonry trowel, apply a 1/2 inch thick, even layer of mortar to the entire back of the veneer. Then press the veneer firmly into place on the prepared wall surface, squeezing the mortar out around all edges. Use a gentle wiggling action while pressing the veneer to ensure a good bond. Use a grout bag to fill joints with mortar and force grout into any voids. Joint grouting can be done as you lay the veneer or after it has all been installed.

Installing Stone with a Full Joint Technique

A full joint is similar to a standard joint, however, the grout level is flush with the face of the veneer. Full joint differs from overgrout whereas the grout does not actually overlap the face of the veneer.

Installing Stone with an Overgrout Technique

Overgrout applications are an increasingly popular way to achieve an old-world appearance. It is a technique that tends to make the masonry-work appear rustic and aged. The grout overlaps the face of the veneer, widening the joints and making them very irregular.

Corner and flat pieces should be installed from the top-down. It is important to fill the mortar joints fully to avoid creating air pockets. If you are tooling the grout joints, use a wooden striking tool instead of a metal striking tool.

Installing Stone with a Dry-Stack Technique

The dry-stack joint look is accomplished by tightly fitting each veneer piece — prior to installation — to ensure a tight fit.

Corner and flat pieces are installed from the bottom-up to allow for a tighter dry-stack pattern. For ease of installation with panelized systems, install one course of veneer (one row of flats and corners) at a time. It is important, when setting the veneer, that the perimeter of the veneer piece is properly sealed with mortar to ensure satisfactory bond and future durability. This can be achieved by following these steps:

- Apply workable mortar generously to the back of each piece to allow ample mortar to squeeze out around all edges as it is pressed onto the wall surface.
- When applying mortar, completely cover the back of each piece and use a trowel to work the mortar into all depressions in the back.
- Immediately after setting each piece, use a masonry trowel to remove any excess mortar and fill any voids along the exposed edges. You can also use a metal striking tool to smooth the mortar around the perimeter.
- Just prior to setting each piece, apply a thin bead of mortar (with a grout bag) to the edges of all previously installed adjacent veneer pieces.

Step 10: Grouting

Grout joints can be various colors. The color of the joints affects the look of the stone significantly. If using a colored grout, Ply Gem Stone recommends a small mock-up panel be made using the colored mortar desired so the customer can see the actual look of the stone with the colored grout. Colored mortar stains are permanent.

Fill a grout bag half full with mortar (see Step 3). Cut the bottom of the cone to allow grout to be squeezed out. The size of the opening can be varied to flow of mortar desired. Squeeze the mortar around each stone, filling tight against the stone below or above or within, to the desired level. When finished, patch all holes even extremely small ones to deny water penetration.

When the mortar joints become thumbprint dry, use a wooden or metal striking tool to rake out the excess mortar to the desired depth. Be careful not to work the joints too soon or the mortar will smear and be discolored. A concave joint will have fewer tendencies to develop hairline cracks at the interface of the stone and mortar.

After working the joints, use a whisk broom or paint brush to smooth the joints and clean away any loose mortar from the joints and stone face. Remember to allow mortar to dry so it is not smeared across the stone. Never allow mortar to cure on the stone face over night because the face will be discolored.

Step 11: Cleaning

After the job is complete, if dirt and debris have accumulated on the stone, the stone may be thoroughly cleaned using detergent/water mixture and a soft bristled brush. This is required if dirt and debris have accumulated on the stone. For difficult stains, use a mild solution of one part white household vinegar to five parts water. Rinse the stone thoroughly when finished. **DO NOT USE ANY ACID CLEANING OR HIGH PRESSURED SPRAYERS.** This will permanently discolor the stone or expose the aggregate.

Step 12: Flashing

Install flashing type and location in accordance with local building code requirements. Corrosion resistant flashing must be installed around all penetrations and terminations of the veneer application. The lower ends of the veneer installation shall terminate four inches above earth surfaces or two inches above paved surfaces with a foundation weep screed unless an alternative method for flashing is approved by the building official. The perimeter of the scratch should incorporate the use of casing bead (minimum 1/2 inch depth), control joints, or other approved accessories.

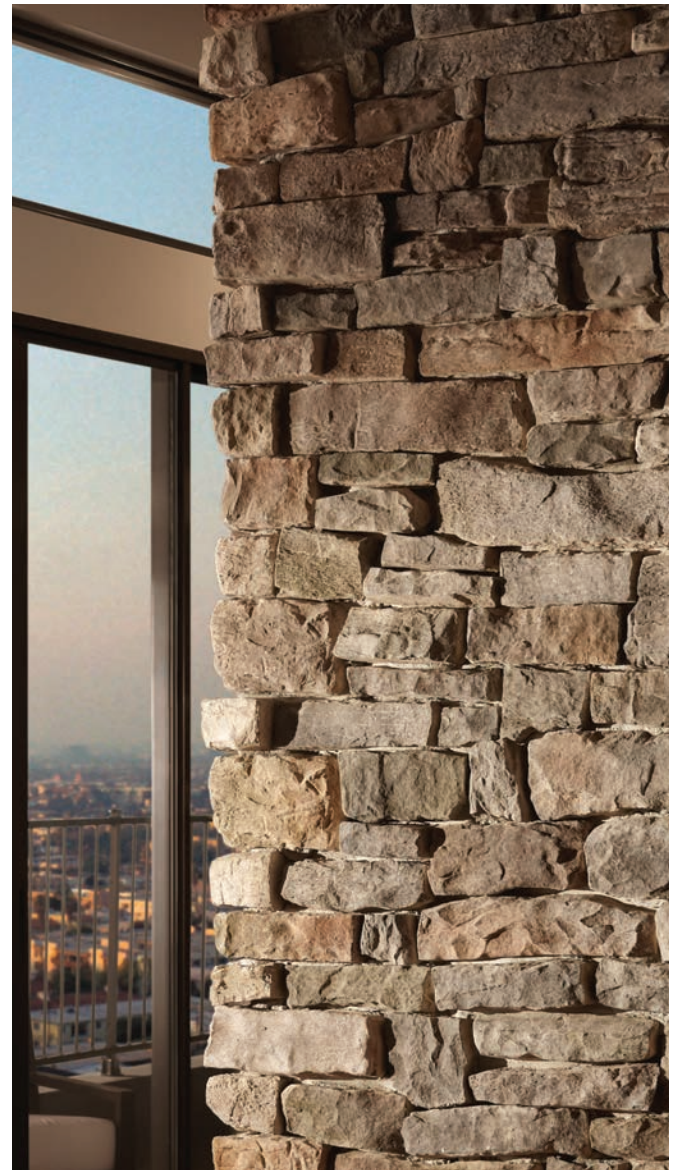

We also recommend...

Water Run-Off

It is important to divert water run-off away from veneer surfaces. Run-off or splashing may stain the veneer. Water run-off combined with freeze/thaw conditions can result in surface damage. Ply Gem Stone should never be used below water level or in applications in which the veneer is subject to chlorine, de-icers, or chemicals that may discolor or adversely affect the veneer. Sprinkler systems should not spray water directly onto stone. Corner or flat veneer pieces should not be used on exterior horizontal surfaces or on cap walls. Use Ply Gem Stone caps and extend them beyond wall surfaces by approximately two inches.

Movement Joints

Expansion joints normally pass completely through a wall. Control joints normally are on the surface of the wall and relieve strain on the skin of the wall. Terminate the veneer installation where control and expansion joints occur in the substrate. Do not span these joints with veneer because this will lead to cracking. Expansion joints in a building must be specified by the architect or engineer.

The architect or engineer should consider the ASTM C 1063 control joint requirements when determining the location of control joints on any structure. Normally the weakest point on a wall is immediately above and below penetrations.

Efflorescence

Efflorescence is usually a white residue that occasionally appears on concrete or masonry surfaces. Efflorescence results from moisture moving through concrete or mortar to the exterior surface. Migrating moisture can carry soluble salts from within the concrete or mortar and deposit them on the face of the product after the moisture evaporates.

To clean efflorescence, scrub affected areas with a soft bristle brush and water. If that does not clean the surface, use a mixture of five parts water to one part white household vinegar. Acids and other cleaning agents or power washing techniques are not acceptable methods of removing efflorescence.

Rainscreen Drainage Plane Systems

Some building codes now require the use of rainscreen damage plane systems behind cladding materials such as manufactured veneer.

If you are installing veneer in these areas or wish to provide additional protection against entrapped moisture, use a rainscreen drainage plane system with the following characteristics:

- The material should be a minimum of six millimeters thick and should not exceed 10 millimeters in thickness.
- The material should be non-absorbent.
- The material should resist compression.
- The material should consist of a two-ply design with a filter fabric (such as spunbonded polypropylene) to prevent the scratch coat from clogging the drainage path.



AUTUMN RIDGESTONE



EASTON FIELDSTONE

- The rainscreen drainage plane material should be rot and corrosion resistant.
- If a strapping system is to be used it should be designed by the architect or an engineer.

The rainscreen drainage plane should be installed on the WRB with the polystyrene drainage plane against the building paper and the filter fabric facing the weather. A metal lath should be installed directly on the filter fabric and attached with either construction nails or a staple gun (to code). A scratch coat is then applied to the metal lath before installing veneer.

Cold/Hot Weather Installations

For cold weather installations, ambient temperature should be 40°F or higher at the time Ply Gem Stone is applied. If the temperature is below 40°F, mortar should be heated between 40°-120°F (not to exceed 140°F). Any mortar that freezes should be discarded. Wall surfaces may need to be covered and heated after installation of veneer to avoid freezing the mortar. Applications in hot weather conditions Mortar should be kept under 120°F and be used within two hours of initial mixing.

Sealers

Sealing the veneer is not required. If you choose to apply a sealer use only a penetrating and breathable silane, siloxane, or silicone-based masonry sealer. We recommend testing a small area first to determine if there are any undesirable effects. Some sealers may alter the color of the veneer by making the surface darker or changing the sheen. Refer to the sealer manufacturer for recommended application, coverage, and maintenance. Sealers should not be applied until a minimum of 1 year after installation of veneer.

Installing to Grade

Ply Gem Stone installations should terminate four inches above earth surfaces and two inches above paved surfaces. Installation should incorporate the use of a weep screed or other code approved flashing. Installations where the veneer will be installed down to grade should be approved by the building code official. See IBC Section 1405.10.1.2; IRC Section R703.12.1 (2009 IRC Section R703.6.2.1); and TMS 402-II Section 6.1.6.2 (ACI 530 Section 6.1.5.2)

During construction, care should be taken to avoid having mud splashed on the stone, in particular around down spouts. Mulch should not be mounded against the stone because it passes moisture into the stone and will stain the stone.

Retaining Walls

Retaining walls in direct contact with soil must be waterproofed and incorporate a drainage system on the side exposed to the soil. A rainscreen drainage system is suggested for the side where stone veneer is to be applied. For installations utilizing hollow block construction, precautions should be taken to prevent water from entering or stagnating in wall cavities before veneer is applied.

Overhead Horizontal Applications

Please verify your installation with your building official and consult with an engineer for specific design issues on your project. There are grout and mortar manufacturers that will support their product's use in these installations. Ply Gem Stone's 50-Year Limited Warranty will still cover our veneer products for manufacturing defects.

Applications in Seismic Zones

Consult with the building official to determine proper selection of mortar type and any installation height requirements. Ply Gem Stone recommends using only Type S mortar in seismic zones.

Flashing Requirements

Type and location of flashing and kickouts should have been installed in accordance with the local building code requirements. Corrosion resistant flashing must be installed around all penetrations and termination of the veneer application. The lower ends of the veneer installation shall terminate four inches above earth surfaces or two inches above paved surfaces unless an alternative method is approved by the building official.

Wind-Load Testing

Ply Gem Stone has tested grouted and dry-stack applications in accordance with ASTM E 330: Standard Test method for structural performance of Exterior Windows, Doors, Skylights, and Curtain Walls by Uniform Static Air Pressure Difference (Modified). Wall samples were subject to positive and negative structural load tests at 57.6 psf (150 mph wind speed) and 60 psf (153 mph wind speed) pressure differentials. After completion of each load, a visual inspection revealed no visible damage or cracking in the veneer.



MIDWEST RIVERSTONE



EASTON LEDGESTONE

Installation Instruction Diagrams

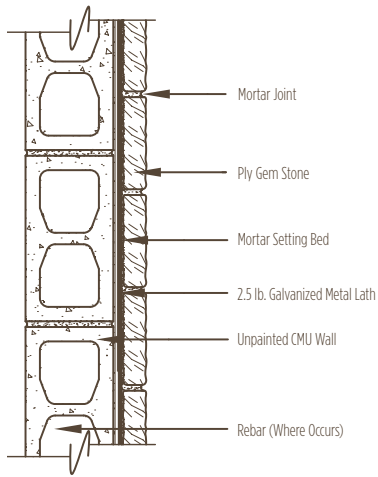

Stone Over Clean CMU Walls

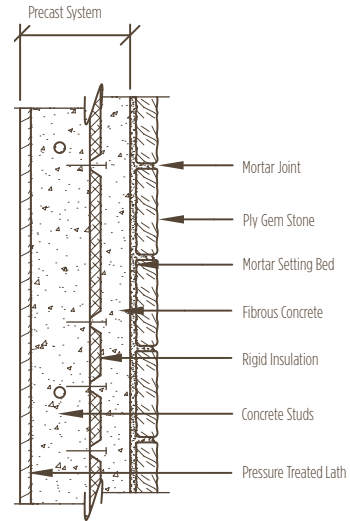

Stone Over Superior Wall Precast Walls

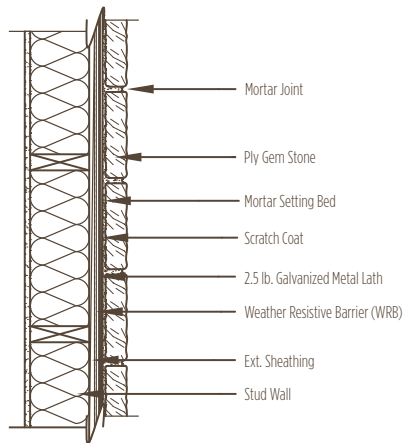

Stone Over Sheathed Wall

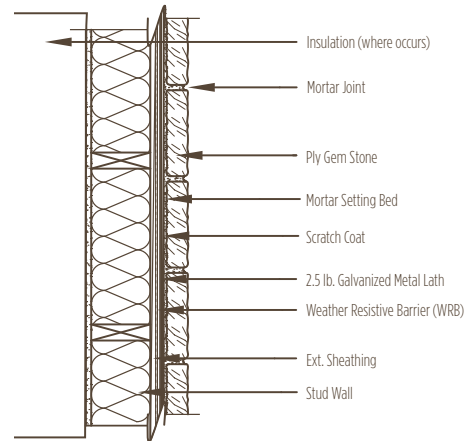

Stone Over Steel Frame

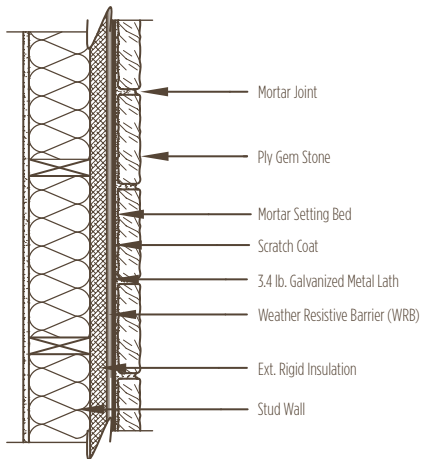

Stone Over Rigid Insulation Wall

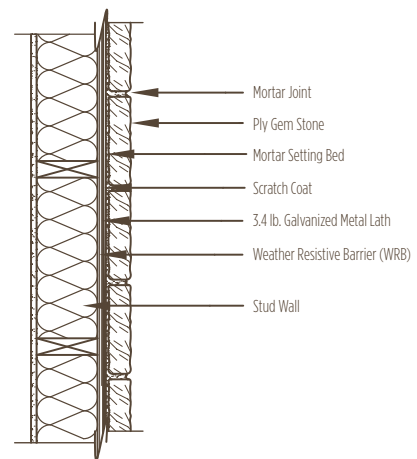

Stone Over Open Stud Cavity

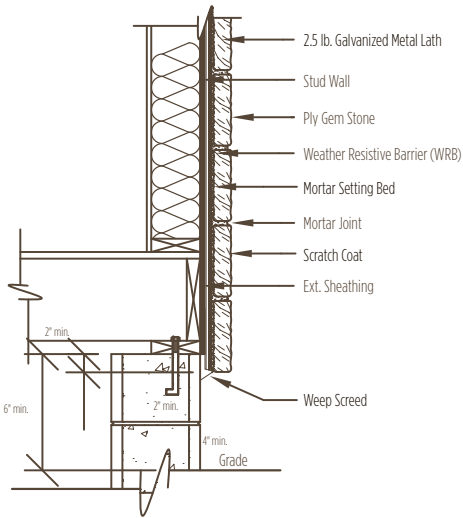

Stone with Weep Screed

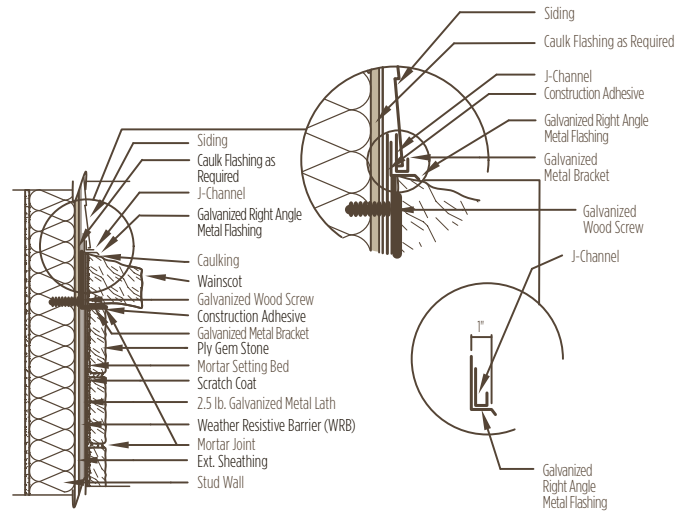

Stone Wainscot Transition

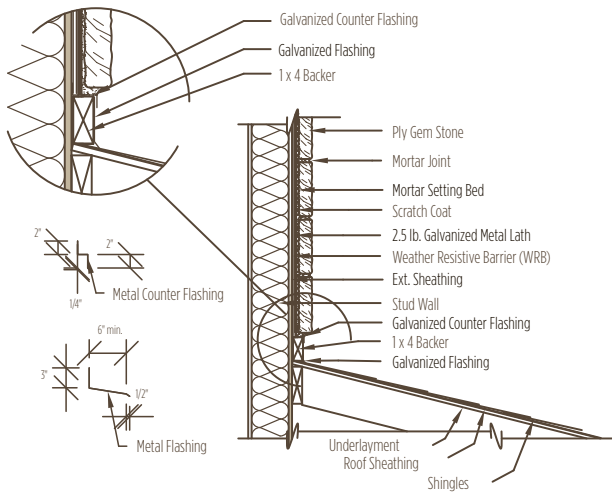

Stone Transition Roof

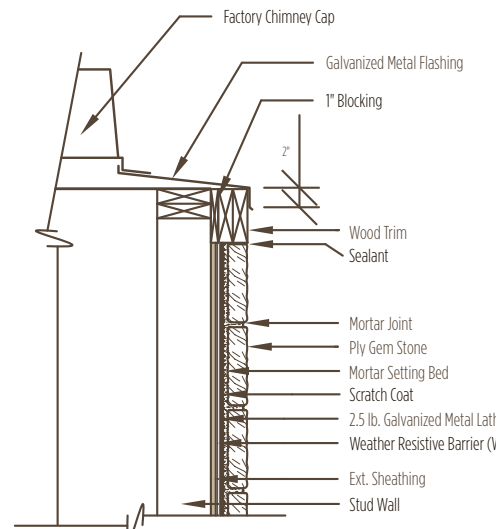

Stone to Chimney Cap

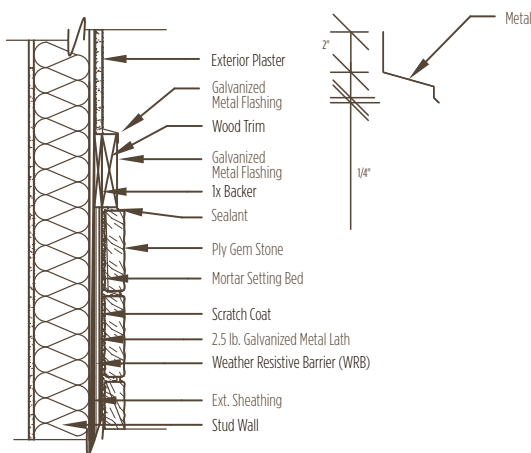

Stone to Wood Trim

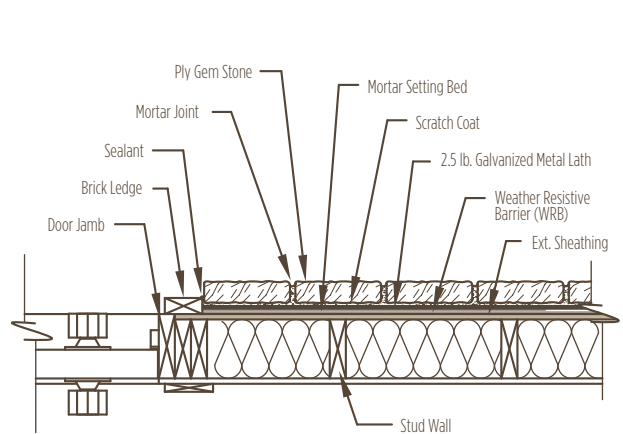

Stone to Door Jamb

Installation Instruction Diagrams

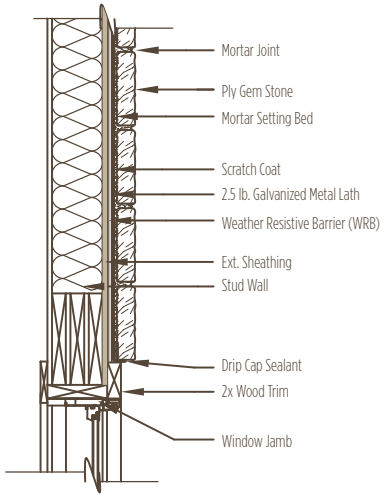

Stone to Window Header

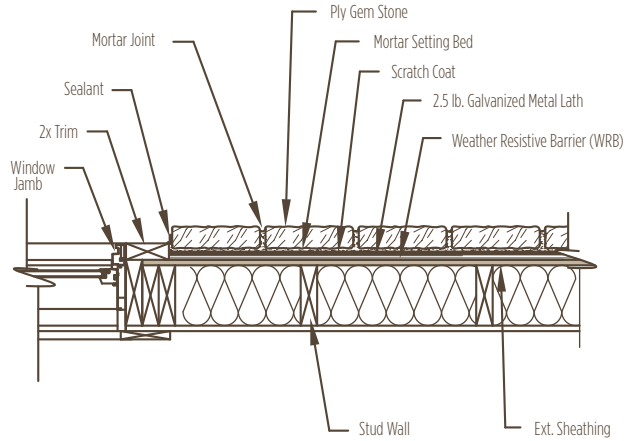

Stone to Window Jamb — Top View

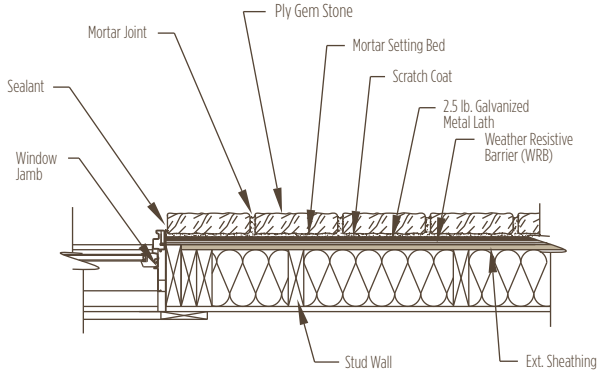

Stone to Window Jamb (Flush) — Side View

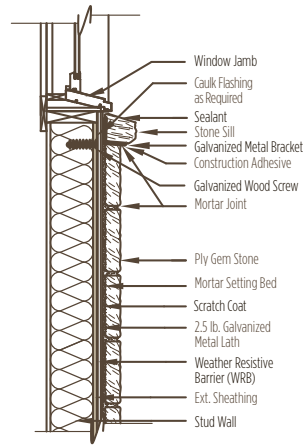

With Stone Sill

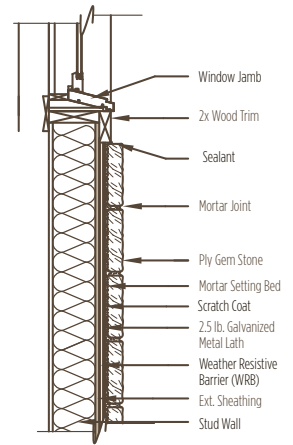

Without Stone Sill

Stone to Window Jamb

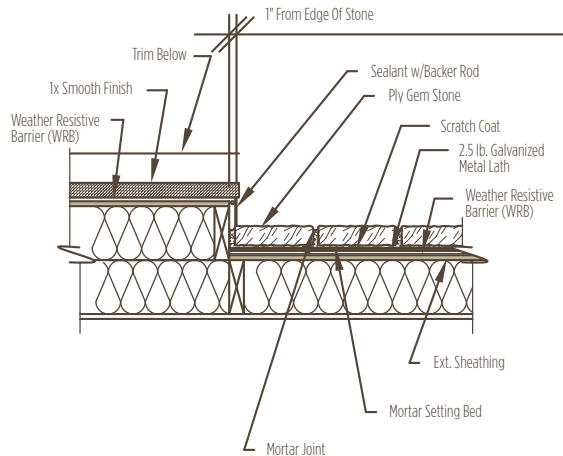

Transition Stone to Siding

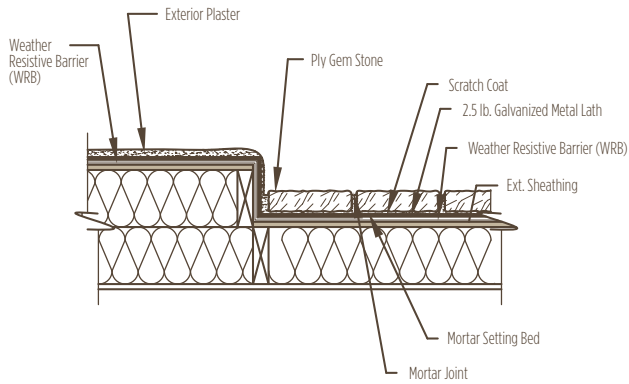

Transition Stone to Plaster

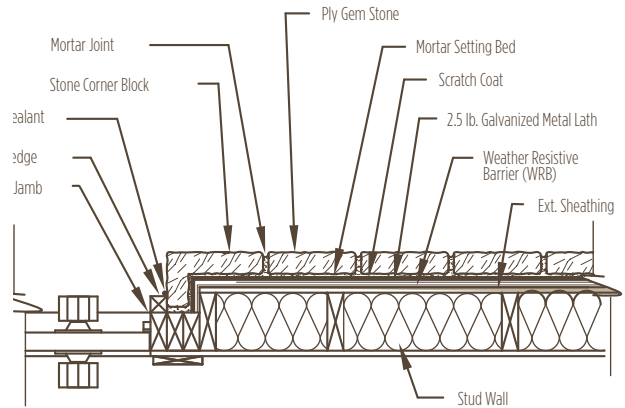

Stone to Door Jamb

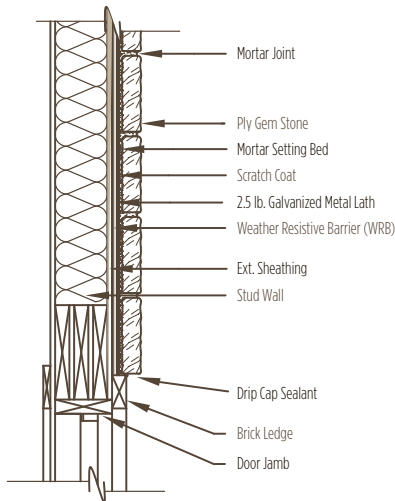

Stone to Door Header

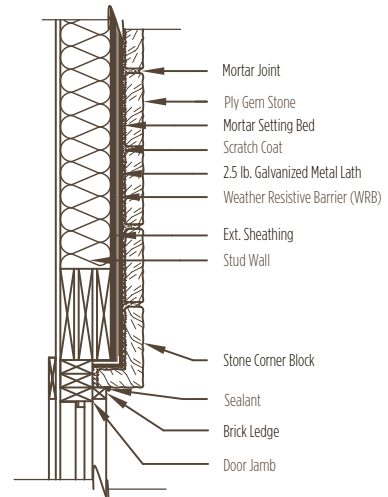

Stone to Door Header

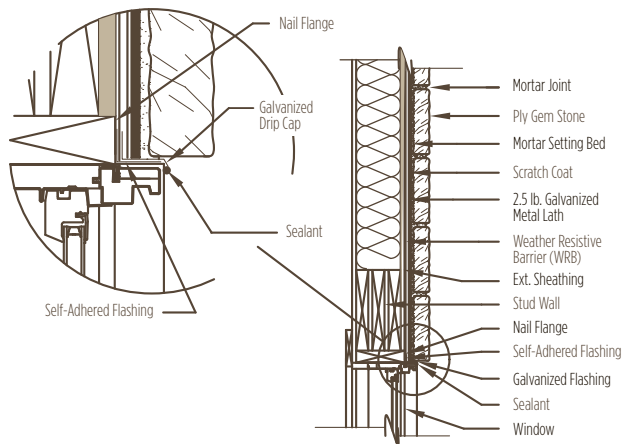

Window/Door Top Flashing

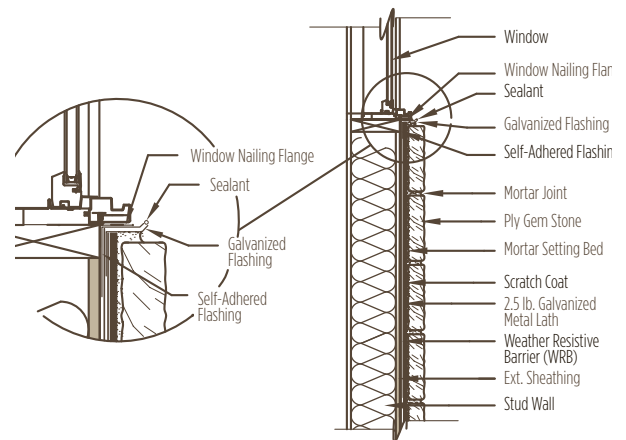

Window/Door Side Flashing

Installation Instruction Diagrams

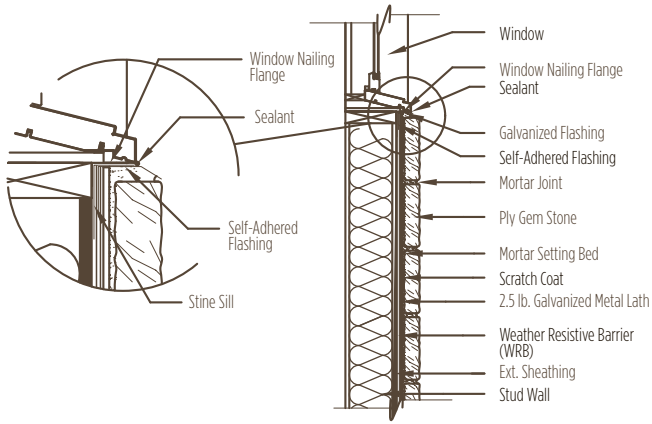

Window Sill Flashing

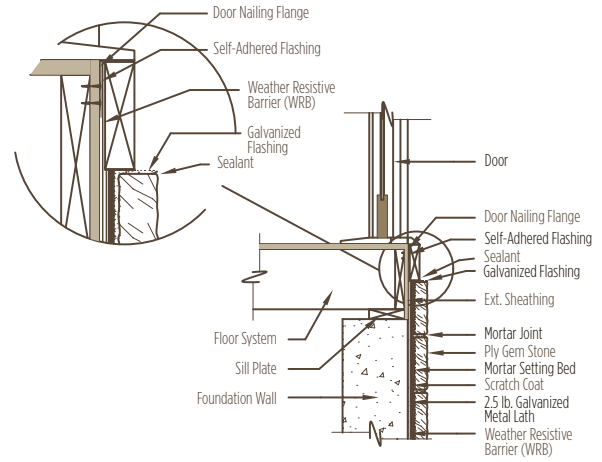

Door Sill Flashing

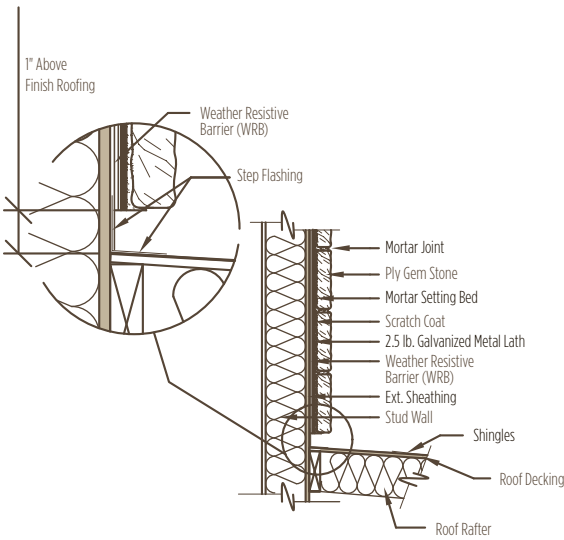

Step Flashing at Roof

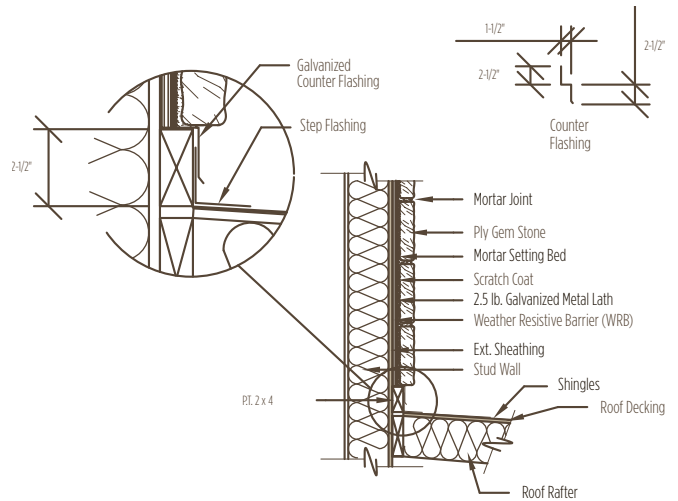

Counter Flashing at Roof/Counter Flashing

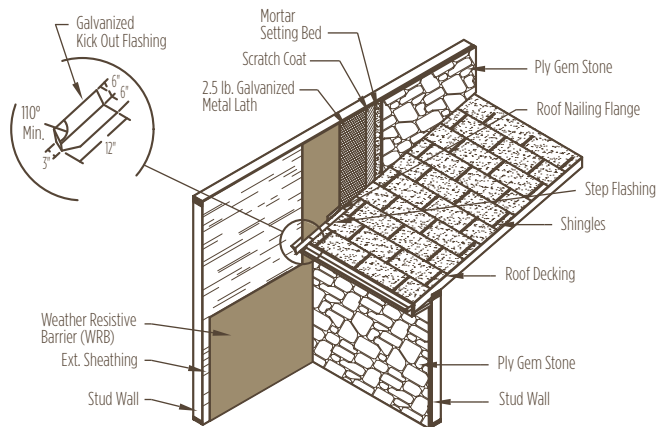

Roof-Wall Kick Out Flashing

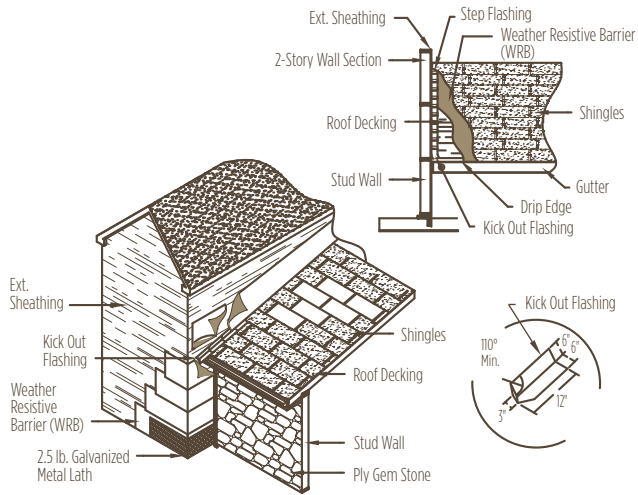

Kick Out Flashing Detail

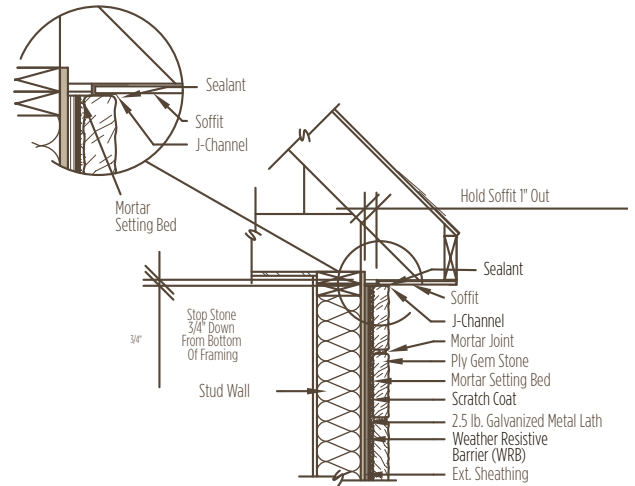

Standard Eave Detail

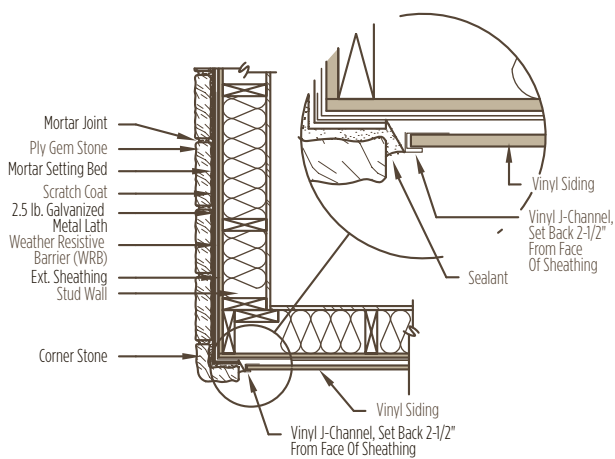

Outside Corner Detail

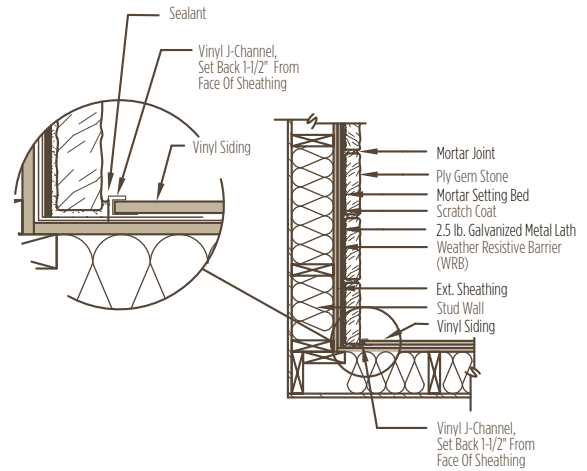

Inside Corner Detail

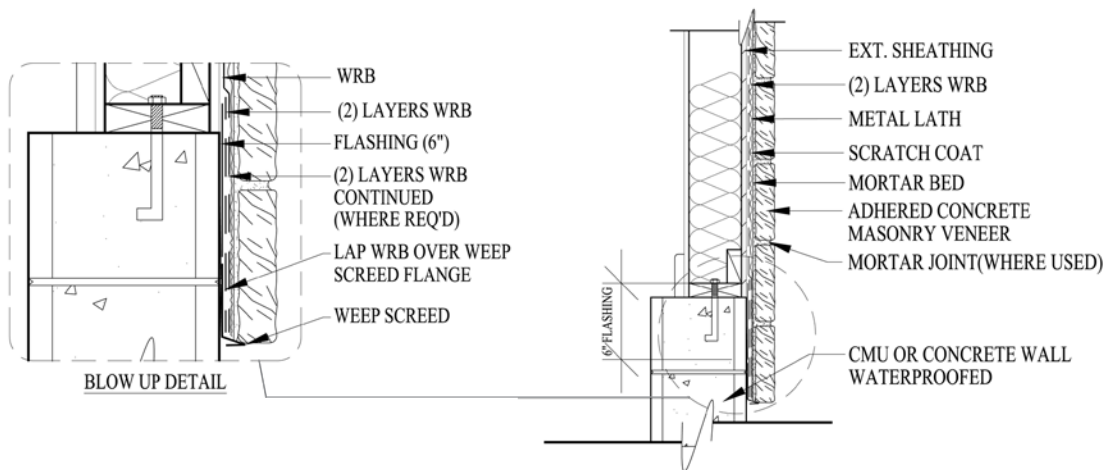

Foundation Wall Base: ACMV Overlapping Foundation

Installation Instruction Diagrams

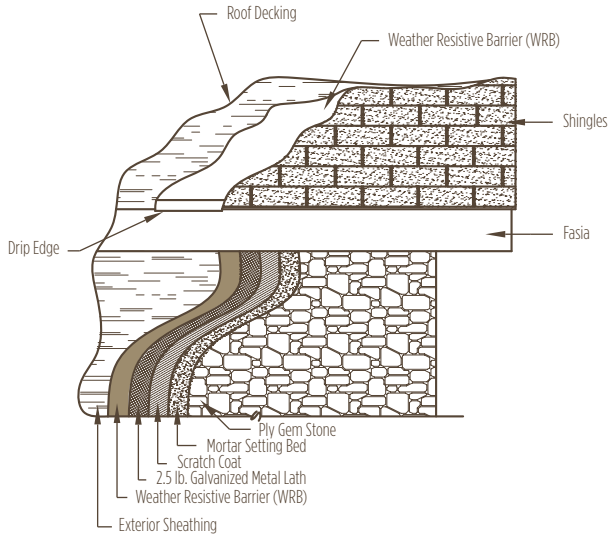

Standard Eave Detail

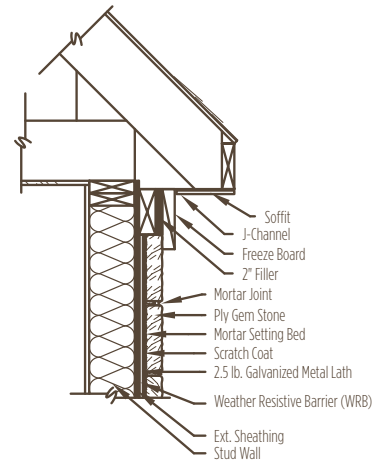

Eave Detail with Frieze Board

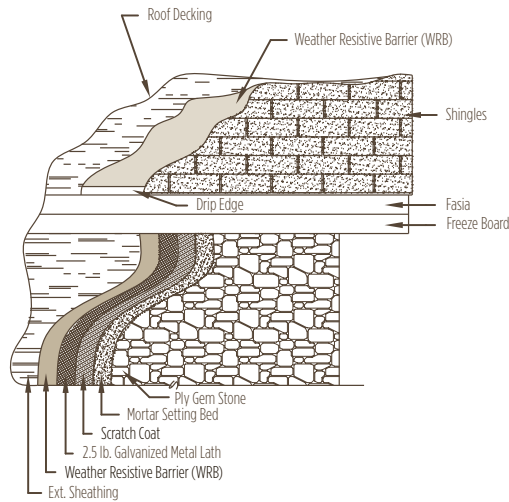

Gable Detail with Frieze Board

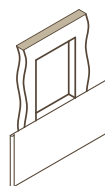

Step #1
Slide First Course
Of Weather Resistive
Barrier (WRB)
Under Sill Flashing

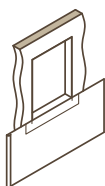

Step #2
Apply Sill Flashing & Sealant

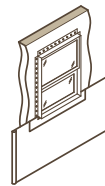

Step #3
Install Window

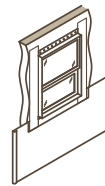

Step #4
Apply Side
Jamb Flashings



Step #5
Apply Head Flashing

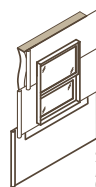

Steps #6 & #7
Apply Subsequent
Courses Of Weather
Resistive Barrier (WRB).

Flashing Window When Using Building Paper

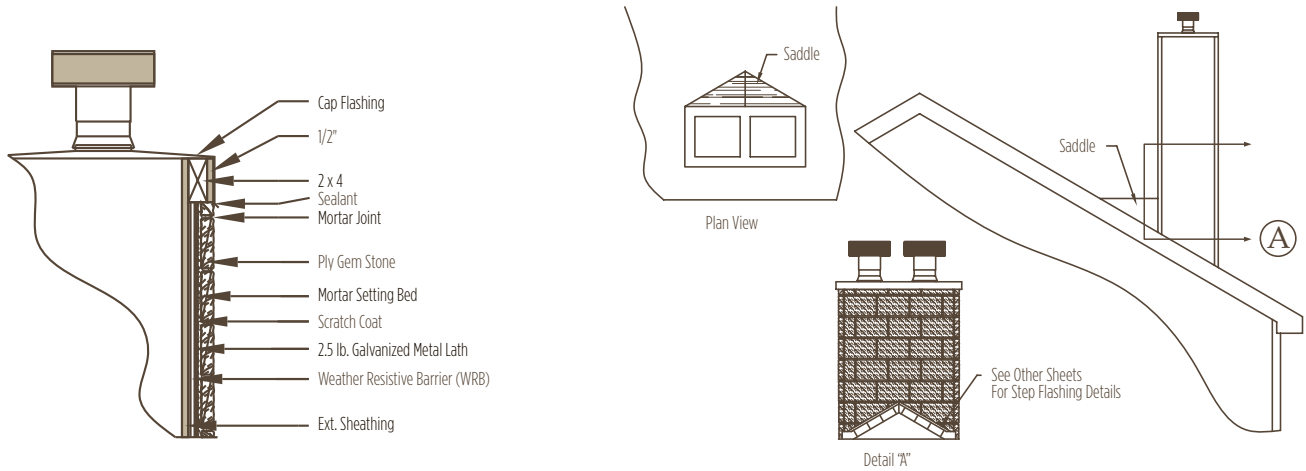

Chimney Cap Detail

Chimney Saddle Details

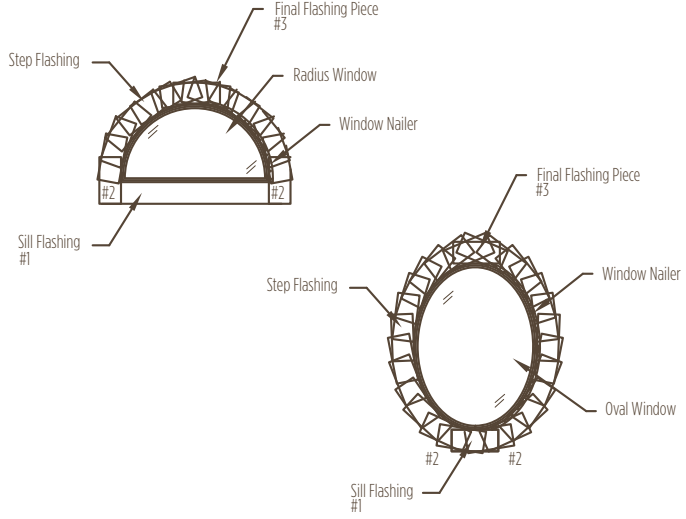

Flashing Around Curved Window Perimeter

Installation Instruction Diagrams

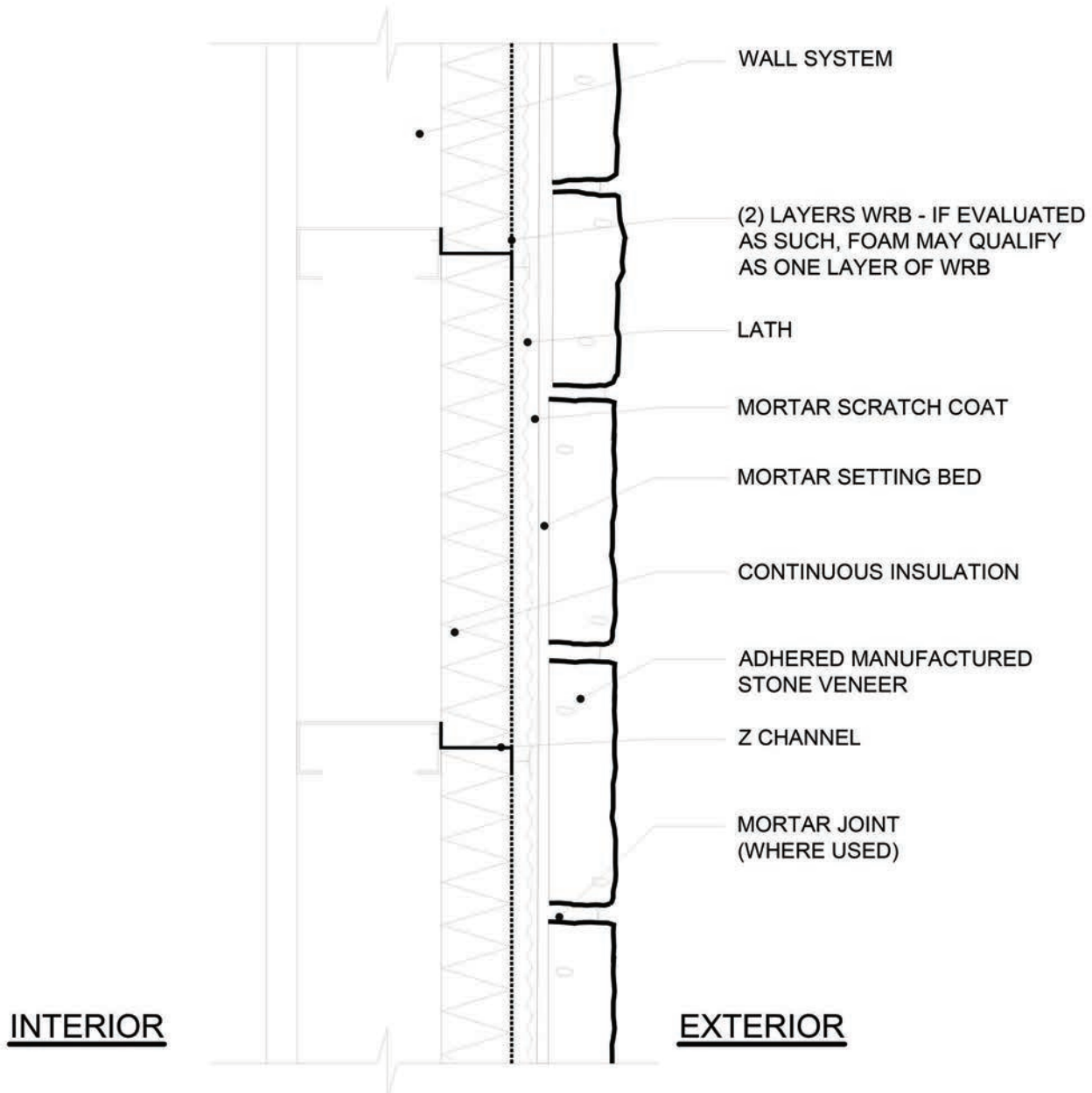

Stone installed over continuous insulated wall

plygemstone.com
2600 Grand Blvd., Suite 900
Kansas City, MO 64108
877-804-1670
support@plygemstoneinfo.com

Because Ply Gem Stone replicates natural stone, inconsistencies in color and texture can be expected. Every effort has been made to ensure the stone colors on our printed and online materials are as close to the actual stone as possible. However, photography, printing, and viewing conditions may alter perception of color. Consult your distributor or sales representative for product samples. Ply Gem reserves the right to alter, modify, or delete items from time to time without notice.

Ply Gem Stone, Ply Gem, and the "Natural Perfection in a Hand-Crafted Stone Veneer" slogan are trademarks of Ply Gem Industries, Inc. and/or its subsidiaries. © 2017 Ply Gem Stone. All products made in the U.S.A. 8109109991108/RevA/MS/0917



Explore our complete line of exterior building products

Ask us about other Ply Gem exterior building products. In addition to Ply Gem Stone, Ply Gem provides a comprehensive line of siding, fence, trim, designer accents, roofing, windows and doors. Everything you need to create stylish, low maintenance exteriors.