

Issue Date: 01-24-2007
Revision Date: 11-06-2019
Renewal Date: 11-01-2020

DIVISION: 06 00 00 – WOOD, PLASTICS AND COMPOSITES
Section: 06 63 00 – Plastic Railings

REPORT HOLDER:

PLY GEM FENCE & RAILING
2600 Grand Blvd, Suite 900
Kansas City, MO 64108
(888) 300-8208
www.plygemrailing.com

REPORT SUBJECT:

Kroy Vinyl Rail Systems:
Kroy Performance Vinyl Railing
Assurance Outdoor Solutions™
Kroy Express Outdoor Solutions™

1.0 SCOPE OF EVALUATION

1.1 This Research Report addresses compliance with the following Codes:

- 2018 and 2015 *International Building Code*® (IBC)
- 2018 and 2015 *International Residential Code*® (IRC)
- 2017 *Florida Building Code* (see Section 9.0)
(Excluding High Velocity Hurricane Zones)

NOTE: This report references 2018 Code sections with [2015] Code sections shown in brackets where they differ.

1.2 *Kroy Vinyl Rail Systems* have been evaluated for the following properties:

- Structural Performance
- Durability
- Surface Burning

1.3 *Kroy Vinyl Rail Systems* have been evaluated for the following uses:

- Guards under the definitions of the referenced codes intended for use on elevated walking areas in buildings and walkways, including stairs and ramps, as required by the referenced codes including Type and Occupancy limitations.

- Provided as level guards for level walking areas such as decks, balconies, and porches, and as sloped guards for open sides of stairways.
- Guardrail systems recognized in this report may be used in One- and Two-Family Dwellings regulated by the IRC and all construction types regulated by the IBC in accordance with IBC Section 705.2.2 and 705.2.3.1 [1406.3], Exception 2 and 3. Guardrails less than 42 inches high are limited to use in One- and Two-Family Dwellings (IRC). See Table 1 for additional restrictions based upon Use and Occupancy Classification

2.0 STATEMENT OF COMPLIANCE

Kroy Vinyl Rail Systems comply with the Codes listed in Section 1.1, for the properties stated in Section 1.2 and uses stated in Section 1.3, when installed as described in this report, including the Conditions of Use stated in Section 6.0.

3.0 DESCRIPTION

3.1 *Kroy Vinyl Railing Systems* are:

3.1.1 Level guards are provided with an overall installed height up to 42 inches and are provided in lengths up to 10 feet (120 inches). See Table 1.

3.1.2 Stair guards are provided with an overall installed height up to that corresponding to a 42-inch level rail and are provided in lengths up to 8 feet (96 inches) sloping length. See Table 1.

3.2 Railings are an assemblage of extruded and molded components utilizing Poly Vinyl Chloride (PVC) material and aluminum reinforcements. Vinyl components are produced in six colors: White, Sandstone, Khaki, Tan, Chestnut Brown, Black, and Almond.

3.3 *Kroy Vinyl Railing Systems* consist of the following components:



3.3.1 The top and bottom rails are extruded PVC profiles of various styles. See Figure 1, Table 1, Table 2, and Table 3.

3.3.2 Balusters are extruded PVC profiles in various dimensions. Some extrusions are reshaped by a thermoform process to simulate a turned spindle design. See Figures 3 and 4 and Table 4 for styles.

3.3.3 An extruded aluminum (6105-T5 or 6005-T5) insert provides reinforcement for the top and bottom rails. Bottom rail reinforcement is utilized in all lengths of stair rails and in lengths of level rails exceeding 8 feet. See Figure 2, Table 2 and Table 3.

3.3.4 Top and bottom rails are connected to posts with molded plastic brackets that are secured to the supports with stainless steel screws. See Figures 5 and 6, Table 2, and Table 3 for brackets. See Table 7 for brackets and fasteners.

3.3.5 A 4-inch square extruded PVC post has a nominal wall thickness of 0.145 inch. See Figure 1.

3.3.6 Kroy Vinyl Railing Systems can be attached to conventional wood supports or a structural PVC post installed with a steel post mount tower. See Figure 10 and Table 5.

3.3.7 PVC post described in Section 3.3.5 can be installed with either the steel post mount tower or used as a non-structural cladding over conventional 4x4 wood posts.

3.3.8 Railing systems include one intermediate support located mid-span beneath the bottom rail. See Figure 9. Exceptions: Rail systems with aluminum inserts in the bottom rail and stair rail systems do not require an intermediate support.

4.0 PERFORMANCE CHARACTERISTICS

4.1 *Kroy Vinyl Railing Systems* have demonstrated the capacity to resist the design loadings specified in Chapter 16 of the IBC when tested in accordance with ICC-ES AC174.

4.2 Structural performance has been demonstrated for a temperature range from -20°F to 125°F.

4.3 Materials used are deemed equivalent to preservative treated or naturally durable wood for resistance to weathering effects, decay, and attack from termites.

4.4 The PVC materials used have a flame spread index not exceeding 200 when tested in accordance with ASTM E84.

5.0 INSTALLATION

5.1 *Kroy Vinyl Railing Systems* must be installed in accordance with the manufacturer's published installation instructions, the applicable Code and this Research Report. A copy of the manufacturer's instructions must be available on the jobsite during installation.

5.2 Railing assemblies consist of top and bottom rails with pre-routed holes to receive balusters. Aluminum railing reinforcements are inserted in the rails during assembly as specified for the type and length of railing. See Table 2 and Table 3.

5.3 Railings attached to wood supports with molded plastic brackets utilize stainless steel "Hi-Lo" wood screws for anchorage. The wood in the supporting structure shall have a specific gravity of 0.50 or greater (Southern Yellow Pine or better) and a minimum thickness to allow full penetration of the bracket mounting screws. Bracket attachment shall be in accordance with Table 7.

5.4 The steel post mount tower shown in Figure 10 may be used for surface mount installations as permitted by Table 5. The steel post mount tower is attached to the supporting structure using four 3/8-inch diameter anchoring bolts with flat washers. The type and length of anchor bolts is dependent upon the material and condition of the supporting structure and is not within the scope of this report.

5.5 Where required by the building official, engineering calculations and details shall be provided. The calculations shall verify that the anchorage complies with the building code for the type and condition of the supporting construction.

5.6 Compatibility of fasteners and other installation hardware with the supporting construction, including treated wood, is not within the scope of this report.





6.0 CONDITIONS OF USE

6.1 Installation must comply with this Research Report, the manufacturer's published installation instructions, and the applicable Code. In the event of a conflict, this report governs.

6.2 Conventional wood guardrail supports are not within the scope of this report and are subject to evaluation and approval by the building official. Supports must satisfy the design load requirements specified in Chapter 16 of the IBC and must provide suitable material for anchorage of the rail brackets. Where required by the building official, engineering calculations and details shall be provided.

6.3 Compatibility of fasteners, post mount brackets, and other metallic components with the supporting structure, including chemically treated wood, is not within the scope of this report.

6.4 The *Kroy Vinyl Rail Systems* are manufactured under a quality control program with inspections by Intertek Testing Services NA, Inc.

7.0 SUPPORTING EVIDENCE

7.1 Manufacturer's drawings and installation instructions.

7.2 Reports of testing and engineering analysis demonstrating compliance with the performance requirements of ICC-ES AC174, Acceptance Criteria for Deck Board Span Ratings and Guardrail Systems (Guards and Handrails), revised December 2014.

7.3 Reports of testing and engineering analysis demonstrating compliance with the performance requirements of ASTM D 7032-14 [-10a], Standard Specification for Establishing Performance Ratings for Wood-Plastic Composite Deck Boards and Guardrail Systems (Guards or Handrails).

7.4 Documentation of an Intertek approved quality system for the manufacturing of products recognized in this report.

8.0 IDENTIFICATION

The *Kroy Vinyl Rail Systems* are identified with the manufacturer's name (Ply Gem Fence & Railing), address and telephone number, the product name (*Kroy Vinyl Rail Systems*), the phrase "For Use in One- and Two-Family Dwellings only" for rails over 8 feet long, the Intertek Mark as shown below, and the Code Compliance Research Report number (CCRR-0106).



9.0 FLORIDA BUILDING CODE

9.1 Scope of Evaluation:

The *Kroy Vinyl Rail Systems* were evaluated for compliance with the 2017 *Florida Building Code*.

9.2 Conclusion:

The *Kroy Vinyl Rail Systems*, described in Sections 2.0 through 7.0 of this Research Report, comply with the 2017 *Florida Building Code* subject to the following conditions:

- Use of the *Kroy Vinyl Rail Systems* for compliance with the High-Velocity Hurricane Zone provisions of the 2017 *Florida Building Code* has not been evaluated and is outside the scope of this Research Report.
- Intertek is a Florida State Product Evaluation Entity.





10.0 CODE COMPLIANCE RESEARCH REPORT USE

10.1 Approval of building products and/or materials can only be granted by a building official having legal authority in the specific jurisdiction where approval is sought.

10.2 Code Compliance Research Reports shall not be used in any manner that implies an endorsement of the product by Intertek.

10.3 Reference to the <https://bpdirectory.intertek.com> is recommended to ascertain the current version and status of this report.

TABLE 1 – MAXIMUM RAILING SYSTEM SIZE AND CODE RECOGNITION

Kroy Vinyl Railing Systems	Code Recognition Maximum Railing Size (Length x Height) ¹	
	IBC	IRC
2" x 3-1/2" STD Rail	96" x 42" Level 87-1/2" x 42" Stair	120" x 42" Level 87-1/2" x 42" Stair
3-1/2" x 3-1/2" T-Rail	96" x 42" Level 87-1/2" x 42" Stair	120" x 42" Level 87-1/2" x 42" Stair

¹Level railing lengths are clear distance between supports. Stair railing lengths are the sloping distance between supports. Railing height is installed height from walking surface to top of top rail. Minimum bottom rail clearance is 2-1/2".

TABLE 2 – LEVEL RAILING SYSTEM DESCRIPTIONS

Kroy Vinyl Railing Systems	Level Railing System Components (See Table 4 for available balusters)	
	Rails	Brackets
2" x 3-1/2" STD Rail	Top: 2" x 3-1/2" STD Rail with Alum. "H" Channel Bottom: 2" x 3-1/2" STD Rail (with Alum. "H" Channel in rail lengths exceeding 8 feet)	Top: OEM, MOD, LMT or Eclipse Bottom: OEM, MOD, LMT or Eclipse
3-1/2" x 3-1/2" T-Rail	Top: T-Rail with Alum. "H" Channel Bottom: 2x3-1/2" STD Rail (with Alum. "H" Channel in rail lengths exceeding 8 feet)	Top: OEM, LMT or Eclipse Bottom: OEM, MOD, LMT or Eclipse

This Code Compliance Research Report ("Report") is for the exclusive use of Intertek's Client and is provided pursuant to the agreement between Intertek and its Client. Intertek's responsibility and liability are limited to the terms and conditions of the agreement. Intertek assumes no liability to any party, other than to the Client in accordance with the agreement, for any loss, expense or damage occasioned by the use of this Report. Only the Client is authorized to permit copying or distribution of this Report and then only in its entirety, and the Client shall not use the Report in a misleading manner. Client further agrees and understands that reliance upon the Report is limited to the representations made therein. The Report is not an endorsement or recommendation for use of the subject and/or product described herein. This Report is not the Intertek Listing Report covering the subject product and utilized for Intertek Certification and this Report does not represent authorization for the use of any Intertek certification marks. Any use of the Intertek name or one of its marks for the sale or advertisement of the tested material, product or service must first be approved in writing by Intertek.





TABLE 3 – STAIR RAILING SYSTEM DESCRIPTIONS

Kroy Vinyl Railing Systems	Stair Railing System Components (See Table 4 for available balusters)	
	Stair Rails	Stair Brackets
2" x 3-1/2" STD Rail	Top: 2" x 3-1/2" STD Rail with Alum. "H" Channel Bottom: 2" x 3-1/2" STD Rail with Alum. "H" Channel	Top & Bottom: OEM, LMT or Eclipse
3-1/2" x 3-1/2" T-Rail	Top: T-Rail with Alum. "H" Channel Bottom: 2" x 3-1/2" STD Rail with Alum. "H" Channel	Top: T-Rail Stair Bracket, LMT or Eclipse Bottom: OEM, LMT or Eclipse

TABLE 4 – BALUSTERS

Available Baluster Styles	
1-3/8" Square PVC Picket	1-3/8" Colonial Spindle

TABLE 5 – POST MOUNTS

Post Mounting System	Code Recognition Maximum Supported Railing Length and Height ¹	
	IBC	IRC
Steel Post Mount Tower (See Figure 12)	96" Length 42" Height	120" Length 42" Height

¹ Railing lengths are clear distance between supports. Railing height is installed height from walking surface to top of top rail. Minimum bottom rail clearance is 2-1/2".

TABLE 6 – ALTERNATE RAILING SYSTEM IDENTIFICATIONS¹

Kroy Performance Vinyl Railing	Assurance Outdoor Solutions™	Kroy Express Outdoor Solutions™
2" x 3-1/2" Open STD	2" x 3-1/2" Standard Rail Kit	2" x 3-1/2" Standard Rail Kit
3-1/2" x 3-1/2" T-Rail	3-1/2" x 3-1/2" T-Rail Kit	3-1/2" x 3-1/2" T-Rail Kit

¹ Each row represents an identical railing system and its identification under the product series name given in the column heading.





TABLE 7 – RAIL BRACKET FASTENING SCHEDULE

Rail – Bracket Combination	Bracket to Post Fastener	Rail to Bracket Fastener
2" x 3-1/2" STD Rail with OEM Bracket	(4) #12 x 1-1/4" Stainless Steel Screws	(2) #8 x 3/4" Self-tapping screws
2" x 3-1/2" STD Rail with LMT Bracket	(4) #10 x 1-1/4" Pan-head, Plated Steel Screws	(2) #10 x 1" Pan-head, Plated Steel Screws
2" x 3-1/2" STD Rail with MOD Bracket	(6) #12 x 1-1/4" Stainless Steel Screws	(2) #8 x 3/4" Self-tapping screws
2" x 3-1/2" STD Rail with Eclipse Bracket	(6) #10-8 x 2" Flat Head Stainless Steel Screws	(4) #10-16 x 1" Pan Head Self-Drilling Stainless Steel Screws
3-1/2" x 3-1/2" T-Rail with OEM Bracket	(4) #12 x 1-1/4" Stainless Steel Screws	(2) #8 x 3/4" Self-tapping screws
3-1/2" x 3-1/2" T-Rail with LMT Bracket	(6) #10 x 1-1/4" Pan-head, Plated Steel Screws	(2) #10 x 1" Pan-head, Plated Steel Screws
3-1/2" x 3-1/2" T-Rail with LMT Stair Bracket	(6) #10 x 1-1/4" Pan-head, Plated Steel Screws	(2) #10 x 1" Pan-head, Plated Steel Screws
3-1/2" x 3-1/2" T-Rail with T-Rail Stair Bracket	(2) #10 x 4" Stainless Steel Screws	(2) #8 x 3/4" Self-tapping screws
3-1/2" x 3-1/2" T-Rail with Eclipse Bracket	(6) #10-8 x 2" Flat head Stainless Steel Screws	(4) #10-16 x 1" Pan Head Self-Drilling Stainless Steel Screws

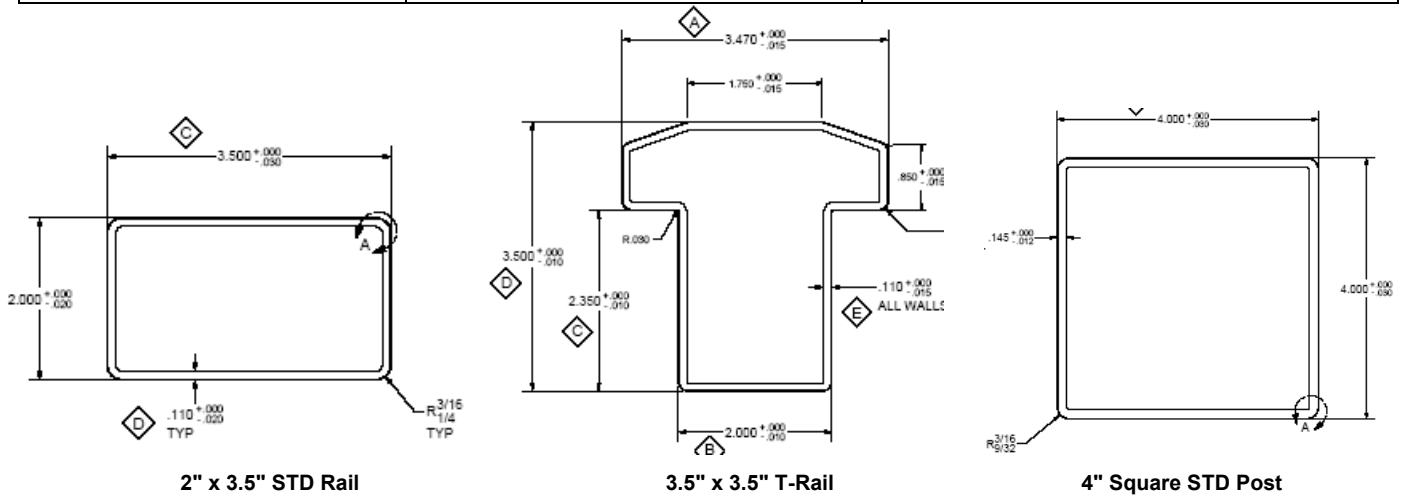

FIGURE 1 – PVC PROFILE DRAWINGS



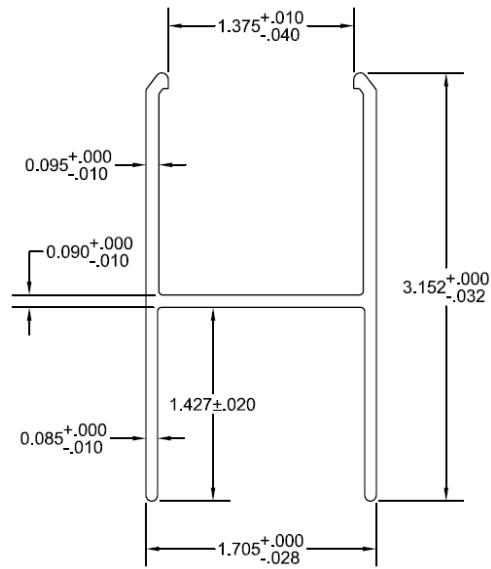
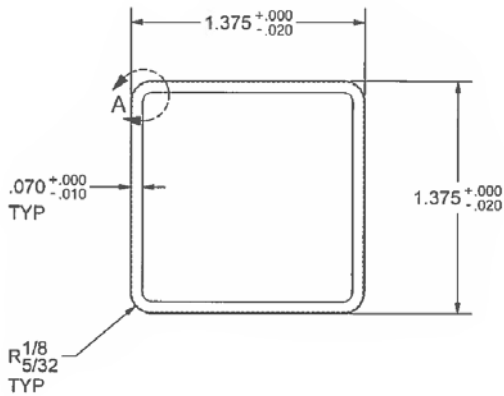

FIGURE 2 – ALUMINUM "H" CHANNEL INSERT



1.375" x 1.375" Picket

FIGURE 3 – PVC PICKET PROFILE



1-3/8" Colonial Spindle

FIGURE 4 – PVC SPINDLE



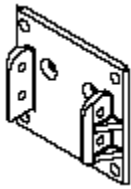

2" x 3.5" OEM Base

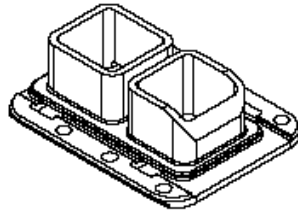

2" x 3.5" MOD Base

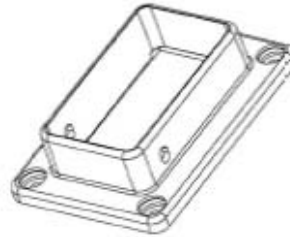

LMT 2" x 3.5" Bracket

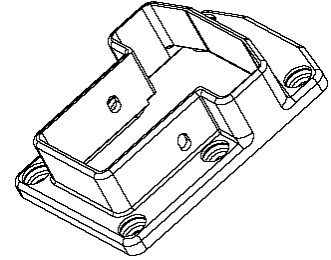

LMT T-Rail Bracket

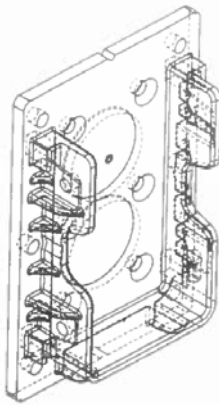

Eclipse 2" x 3-1/2" STD Top and Bottom Rail Straight Bracket

(Also used for T-Rail Level Bottom Rail)

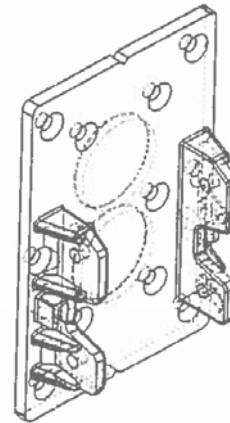

Eclipse 3-1/2 x 3-1/2" T-Rail Straight Top Bracket

(Also used for T-Rail Stair Top)

FIGURE 5 – MOLDED PLASTIC STRAIGHT RAIL BRACKETS

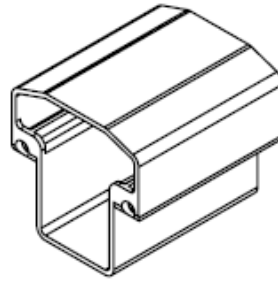

T-Rail Stair Bracket ⁽¹⁾

(1) Note: T-Rail stair brackets are field cut for a flush fit to the supporting surface with an angle corresponding to the stair slope. The cut end shall be limited to providing the required angle and shall not reduce the overall length of the bracket.

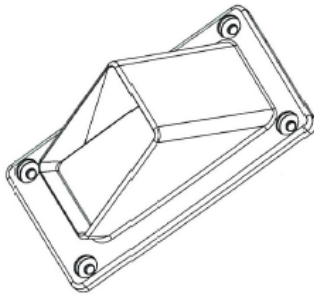

LMT 2 x 3.5 Stair Bracket

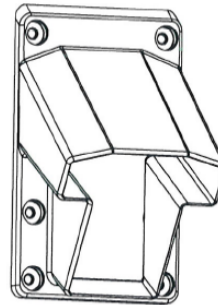

LMT T-Rail Stair Bracket

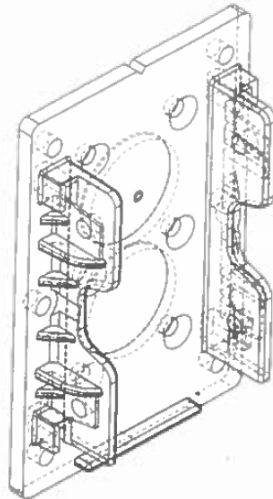

Eclipse 2" x 3-1/2" STD Rail Top and Bottom Stair Bracket
(Also used for T-Rail Stair Bottom Rail)

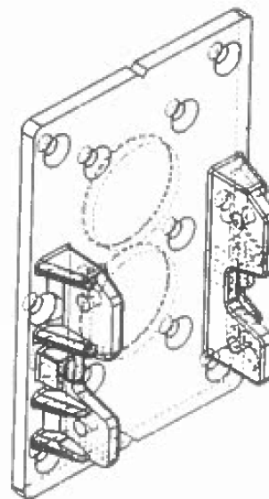

Eclipse 3-1/2" x 3-1/2" Top T-Rail Stair Bracket
(Also used for T-Rail Level Top Rail)

FIGURE 6 – MOLDED PLASTIC STAIR RAIL BRACKETS

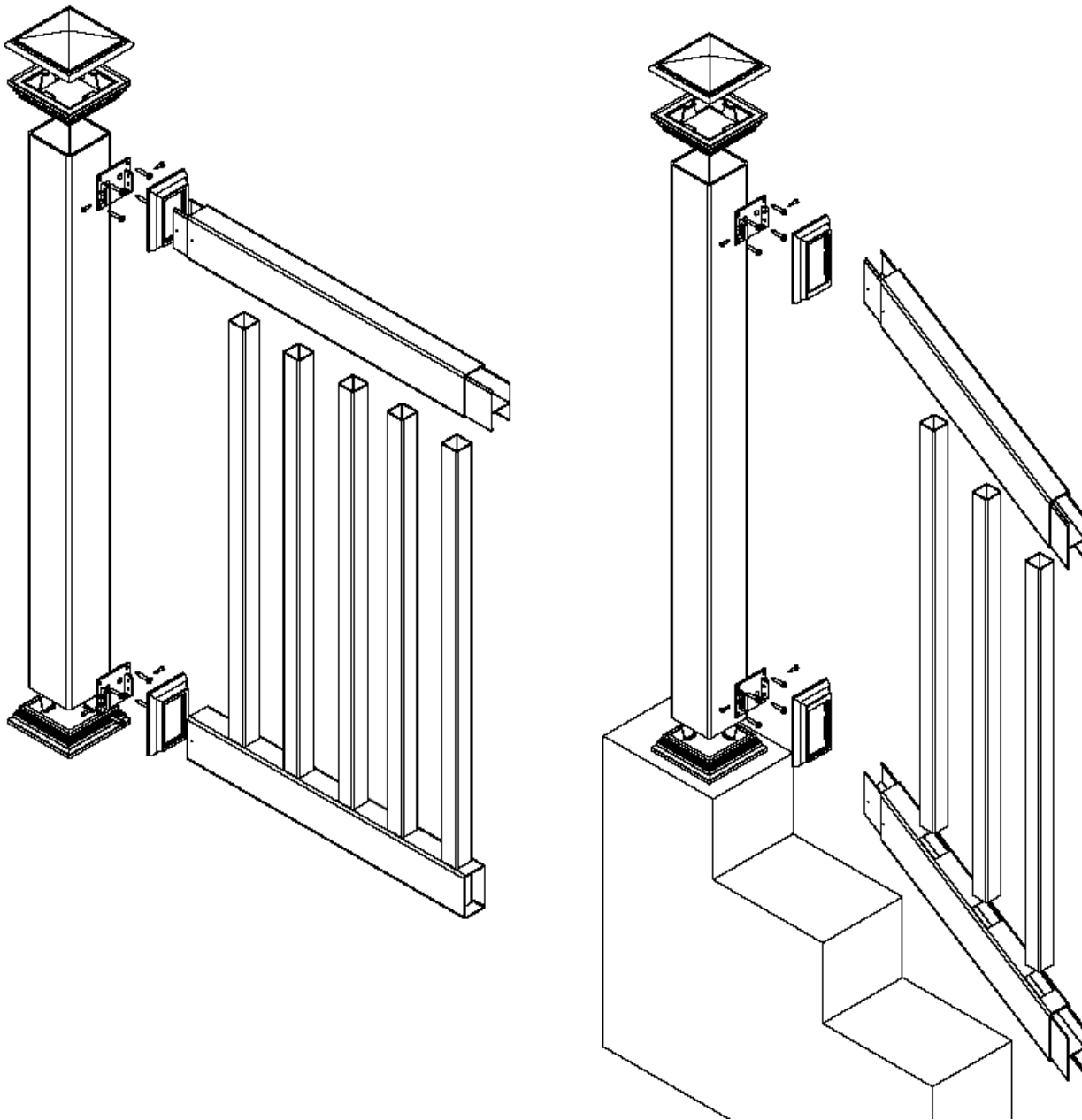

FIGURE 7 – 2" X 3-1/2" STD RAIL (Level and Stair)
Bottom rail reinforcement not shown for level rail. See Table 2 for requirement.

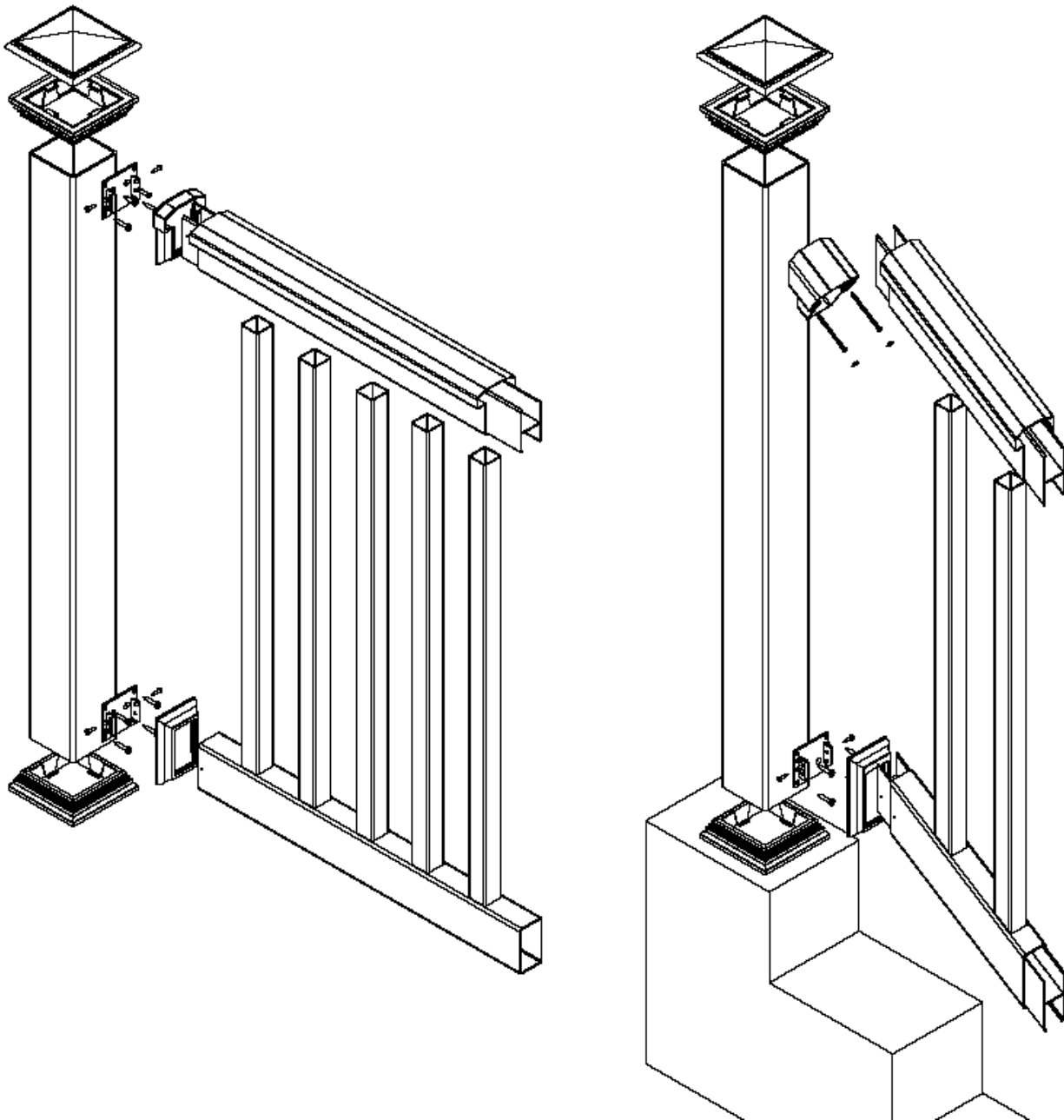
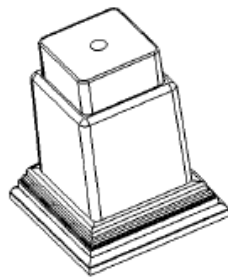

FIGURE 8 – 3-1/2" X 3-1/2" T-RAIL (Level and Stair)
Bottom rail reinforcement not shown for level rail. See Table 2 for requirement.



#12 x 1.0" Phillips head, self-tapping, stainless steel retaining screw (typ. top and bot.)

LMT Foot Block

FIGURE 9 – BOTTOM RAIL INTERMEDIATE SUPPORT (FOOT BLOCK)

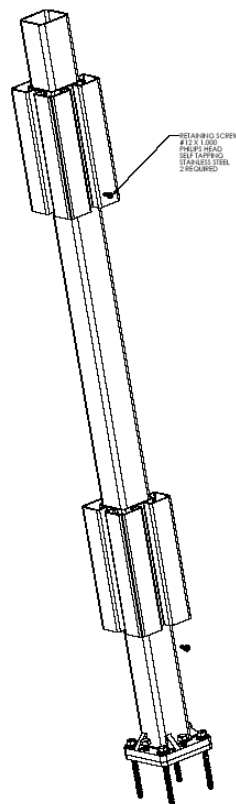

FIGURE 10– STEEL POST MOUNT TOWER

Note: Anchorage and supporting structure are not within the scope of this report and must be designed and constructed in accordance with Chapter 16 of the IBC.

1. Minimum anchorage is (4) 3/8" bolts. Length and type as appropriate for the type and condition of the supporting structure.
2. Molded PVC Guide Blocks are located at top and bottom rail bracket connection.