

Classic Patio Door Installation Instructions

RECOMMENDED TOOLS & ACCESSORIES

(Not supplied by Ply Gem)

- Phillips Head Screwdriver
- Flat Head Screwdriver
- Level (3' or longer)
- Framing Square
- Hammer or Staple Gun (See Fastener Schedule)
- Utility Knife
- Shims
- Exterior-Grade Sealant (Suitable for Door & Window Installation)
- ASTM-Approved Flashing Membrane
- Fasteners (See Fastener Schedule)



IMPORTANT! READ ALL INSTRUCTIONS BEFORE BEGINNING INSTALLATION.

This door unit has been engineered and manufactured to provide superior weather protection and service.

The manufacturer warrants this product only when installed according to these instructions. The manufacturer will accept no responsibility for air or water leakage above, under, or around the door unit. The recommended flashing details depicted in these instructions are a general guide. Refer to the flashing manufacturer's application instructions when possible.

Do not paint any part of this unit for any reason. Painting will render null and void all warranties.

Step 1: Unpacking Door

1. Remove the outer boxes and skid boards, taking care not to damage the nail fins.
2. Rotate the door 90° so that the aluminum roller track is close to the floor.
3. Remove the bumper that is placed in the active panel track to prevent movement during shipment (**Figure 1**). Move the active panel and place the bumper in the track at the top corner behind the stationary panel.
4. Do not remove the performance labels. These are required by building inspectors, and should only be removed by the end user.

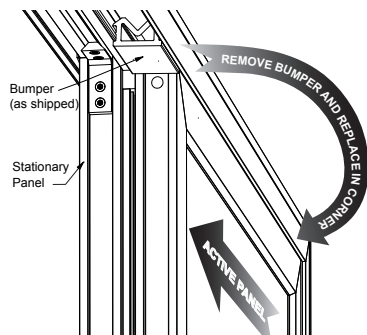

Figure 1 — Remove and Replace Bumper

2. The handing of this door product is easily reversible. If it is determined that the handing of the door needs to be changed, proceed directly to Step 7 of these instructions for information on handing reversal.

Step 3: Remove the Active Panel

1. Slide the active panel to the center of the door.
2. Retract the rollers completely. The adjustment screws can be accessed by removing the small cover plug at the lower edge of each side of the active panel. Keep the cover plugs to reinstall later. Insert a Phillips head screwdriver into the hole until the adjustment screw is engaged. Turn the screw counter-clockwise to retract the rollers (**Figure 3**).
3. Lift the panel up and swing the bottom edge out, then slightly lower the panel until the top edge clears the frame (**Figure 4**). Carefully set aside for reinstallation later.

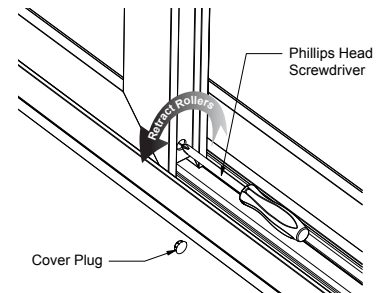

Figure 3 — Retract Rollers

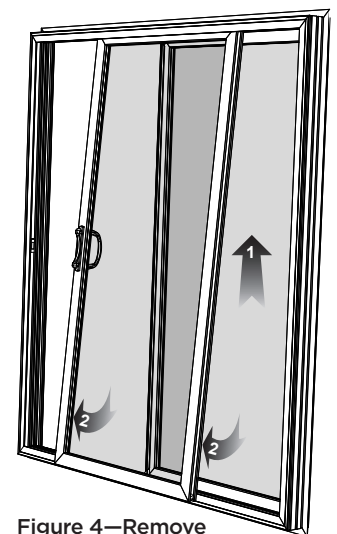

Figure 4—Remove Active Panel

Step 2: Determine Handing of Door

1. While viewing the door from the exterior, with the active panel in the closed position, the door is right-handed if the handle is on the right. It is left-handed if the handle is on the left (**Figure 2**).

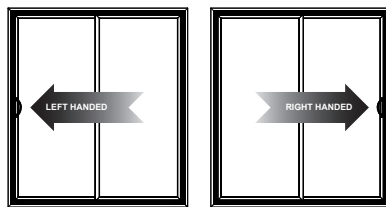

Figure 2 — Handing viewed from exterior (doors shown in closed position)

Step 4: Install the Frame

1. Inspect the frame. There are four weep covers on the exterior face of the frame. The two at the top (head) should be solid, and the two at the bottom (sill) have a flap that allows water out, and deters entry by insects.
2. Check the opening for correct dimensions. The opening should be 1/2" wider and 1/2" taller than the frame. Do not include the nail fin when measuring frame dimensions. The opening should be plumb and square.
3. The sill must be level, flat and clear of dirt and debris that would prevent a good weathertight seal.
4. **(Recommended)** Apply flashing to the sill where the door will sit, extending up each side of the opening as shown (**Figures 5 & 6**).

Cut 9" wide flap into weather-resistant barrier as shown

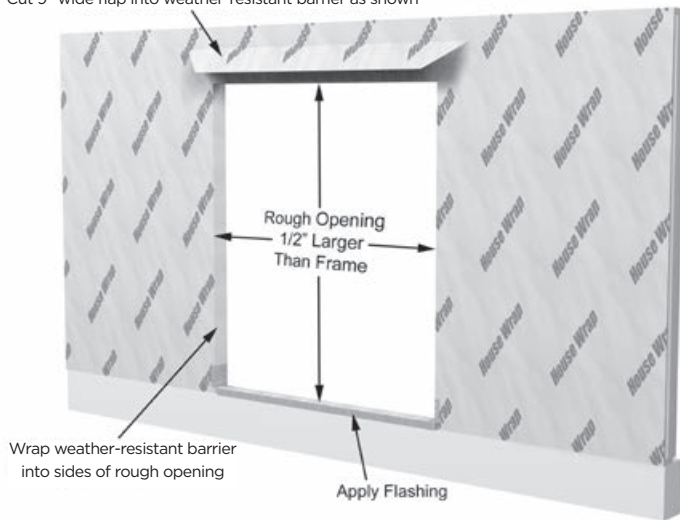

Figure 5 — Typical Rough Opening

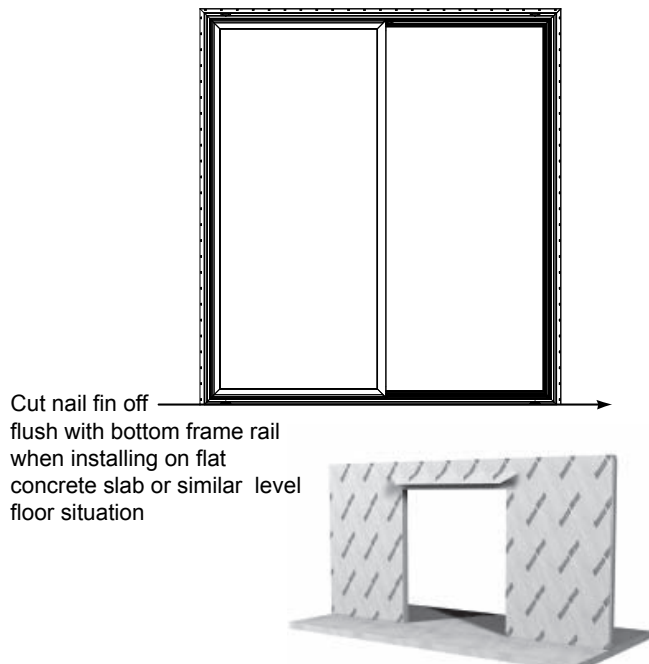

Figure 6—Rough Opening With a Flat Floor

5. Apply three 3/8" diameter beads of sealant across the entire length of the sill, or bottom surface of the rough opening.
6. Apply a bead of sealant around the entire door, on the nail fin surface that will contact the house.
7. Using at least two people, lift the door from the exterior of the home into the center of the opening and seat into the sealant. Set a single fastener top center and bottom center to hold the door in place.
8. If there is a gap between the framing of the wall structure and door frame, place shims in at least three places per side and top (**Figure 7**). Do this from the interior of the home. Shims should be snug, but should not deform the frame.

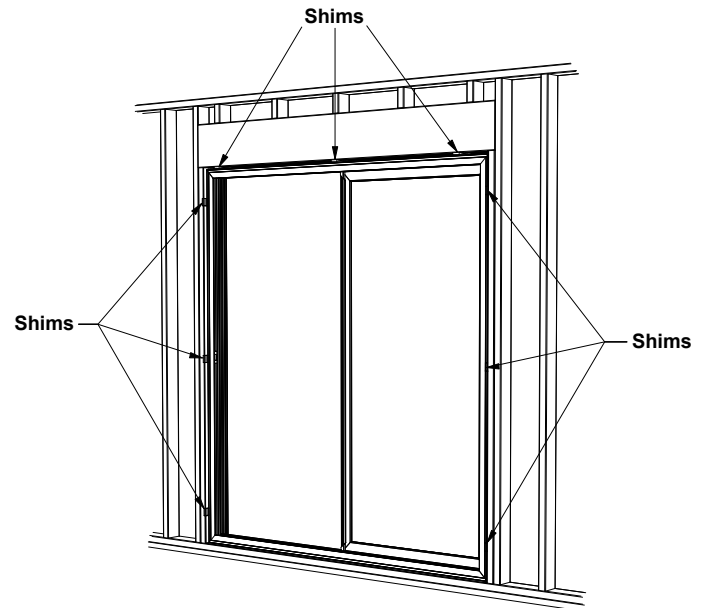

Figure 7—Shim Location

9. Using the framing square and level, verify that the door frame is square and level, and adjust as needed before proceeding with the installation. Check for level at the top and bottom of active panel opening.
10. Set the fasteners in the nail fin holes provided around the perimeter of the frame. These doors **require** one fastener in every hole. Check the frame to ensure it is square during and after the fastener installation.

Approved Fasteners

All Fasteners should be corrosion resistant.

#6 x 3/4" Pan-head Screw

9/16" x 2" x 16 Gauge Staple

2" Ring Shank Nail

3" Wood Screw and Fender Washer

11. Drive a 3" wood screw with a 1-1/4" diameter fender washer up into the header at the center of the frame, in the center of the active panel track. An 8-0 x 8-0 door requires three screws evenly spaced along the header.

Step 5: Install Active Panel

1. Inspect the aluminum panel track to be sure it is seated properly into the frame, and has not been bent or damaged.
2. Lift the active panel and center it on the frame. Insert the top of the panel into the head track. Lift until the bottom of the panel clears the sill, and rotate it into the frame. Carefully lower the frame onto the track.
3. With the door still centered in the frame, adjust the rollers so that the door is equally spaced at the top and bottom. This should provide approximately 1/2" of coverage of the top and bottom of the active panel.
4. Check the door for proper operation by rolling it back and forth.
5. Replace the roller adjustment cover plugs previously removed in Step 3 when you are done.
6. Refer to the handle instructions for handle and strike installation.

Step 6: Finishing Installation

1. **(Recommended)** Install the side flashing, making sure to lap over the sill flashing and cover all of the fastener heads (**Figures 8 & 9**).
2. **(Recommended)** Install Head Flashing, making sure to lap over Side Flashing and cover all fastener heads (**Figures 8 & 9**).
3. From the interior, fill the voids between the door frame and house framing with insulation. If using aerosol foam, use only low expanding foam conforming to AAMA 812-04.
4. Trim the interior as desired, taking care not to drive the fasteners into the vinyl frame.
5. After the exterior siding has been installed, seal the joint between the siding and the door frame.
6. Remove the blue painters tape from the weep flaps (in two places) to ensure proper weep operation.

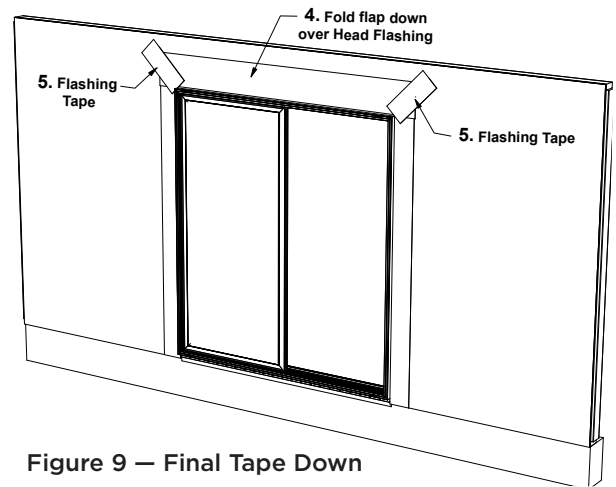
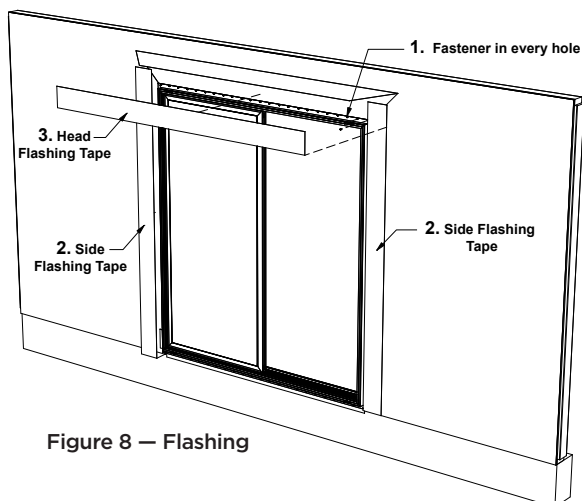

Step 7: Handling Reversing Instruction — Prior to Door Installation

⚠ NOTE: DOORS MEASURING 90" AND TALLER CANNOT BE REVERSED. DO NOT ATTEMPT TO REVERSE THESE DOORS.

1. Holding the aluminum components, place the door so that the sill lays flat on a horizontal surface.
2. Remove the following components from the door and place to the side (**Figure 10**):
 - A. Active panel - remove as described in Step 3.
 - B. Aluminum screen track - a flat head screwdriver might be required to loosen the track from the frame.
 - C. Aluminum active panel track - a flat head screwdriver might be required to loosen the track from the frame.
 - D. Aluminum threshold - a flat head screw driver might be required to loosen the threshold from the frame.
 - E. Active panel bumper (**Figure 1**)
 - F. Weep hole covers and plugs

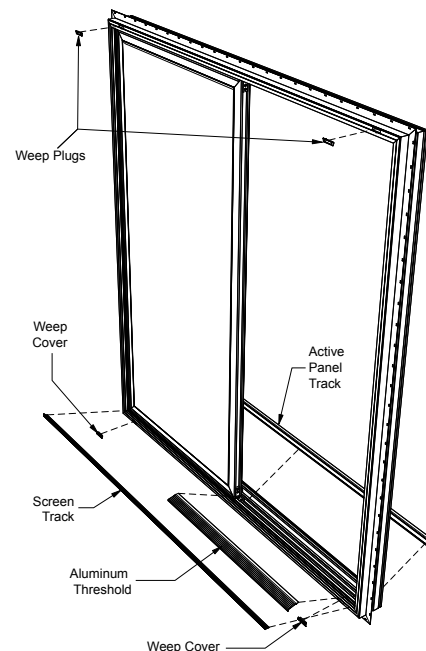

Step 7: Handing Reversing Instruction—Prior to Door Installation (Continued...)

3. Rotate the entire door assembly 180° so that what was the sill, is now the head.

4. On the Active Panel:
 - A. Remove the two Phillips head screws attaching each roller to the door panel (**Figure 11**).

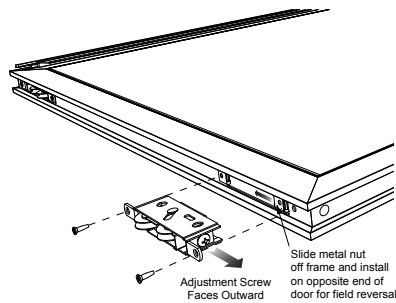

Figure 11 — Roller Removal

- B. Remove the two roller assemblies from the door panel.
- C. Remove the two sheet metal nuts from each of the roller cavities in the door panel.
- D. Reinstall the sheet metal nuts and the roller assemblies in the opposite end of the door panel, making sure that the roller adjustment screws are facing the outside edges of the door panel.

- E. From the interior side of the door panel, remove the two long Phillips head screws from the door handle and remove both the interior and exterior handle assemblies (**Figure 12**).

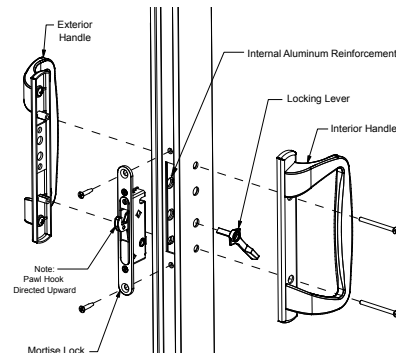

Figure 12 — Handle & Lock Components

Remove the locking lever. Place one of the long screws from the handle assembly into one of the handle holes in the door panel to prevent the internal aluminum reinforcement from shifting.

- F. Remove the two Phillips head screws attaching the mortise lock to the door panel. Remove the mortise lock and rotate it 180°. The latch pawl hook must be in position to engage upward. Replace the mortise lock screws and the lock and handle hardware in reverse order, making sure that the latch lever and handle screws are on the new interior side of the door panel.
5. With the door frame in its new orientation, replace the aluminum active panel track, aluminum screen track, aluminum threshold and the weep plugs and covers. The weep covers with the operating flap must be at the bottom of the frame with the flap hinge up. Replace the active panel bumper in the top corner of the active panel track behind the stationary panel (**Figure 1**).

Step 8: Handing Reversing Instruction—After Door Installation

⚠ NOTE: DOORS MEASURING 90" AND TALLER CANNOT BE REVERSED. DO NOT ATTEMPT TO REVERSE THESE DOORS. If it is determined that the door is improperly handed after installation, it can be reversed.

1. Remove the active panel as described in Step 3. Remove the aluminum threshold, and active panel bumper from the frame as described in Step 7-2.
2. Perform the reversal operations to the active panel as described in Step 7-4.

3. On the stationary panel, remove the Phillips head and safety torx screws attaching one of the anchor shoes to the panel and the door frame. The required T25 safety torx bit (part # 252951) may be purchased from Ply Gem Windows, if needed. Remove the anchor shoe and reinstall one of the Phillips head screws back into the stationary panel. This will hold an internal reinforcement in place. Remove the other anchor shoe.

4. On the exterior of the panel, carefully remove the retainer strips located around three sides of the panel that contact the frame (**Figure 13**).

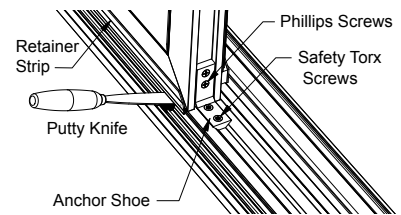

Figure 13 — Clip & Anchor Shoe

5. From the interior of the home, insert a deglazing tool or putty knife between the door panel and the frame parting bead. Run the tool around the three sides of the panel that are in contact with the frame. Use caution and be prepared, as the freed panel is heavy. Remove the door panel from the frame.
6. Clean any tape residue from the door panel and the frame parting bead. Carefully clean the bulk residue with a putty knife. Clean the remaining residue with Goof Off or similar cleaning product. Wipe clean with denatured alcohol.
7. On desired side of the frame, apply clear silicone across head, sill and side jamb.
8. Rotate the stationary panel 180° from the original orientation, and reinstall onto the desired side of the frame. The panel must rest on the sill, and against the side jamb with the interlock to the center. A small gap (1/32") should be present between the top of the panel and head of the frame.
9. Reinstall the retainer strips and anchor shoes in reverse order.
10. Reinstall the active panel bumper in the top corner of the active panel track in the frame, behind the stationary panel. Reinstall the aluminum threshold and the active panel.
11. Remove the active panel strike from the door frame, and reinstall it on the opposite side of the frame, locating it with the dimples provided in the frame.