

## Mulling Instructions for 1500 Vinyl Windows (Beveled Frame)

### TOOLS NEEDED

- Utility Knife
- Chisel
- Tape Measure
- Mallet
- Phillips Head Screwdriver
- Sealant Gun

### SUPPLIES NEEDED

- Exterior-grade Sealant
- Hacksaw (optional)
- Duct Tape



**READ ALL INSTRUCTIONS BEFORE BEGINNING INSTALLATION.**

**THOROUGHLY REVIEW PARTS LIST AND CHECK EACH WINDOW AND THE MULL KIT FOR POSSIBLE TRANSIT DAMAGE.**

**IMPORTANT: CONSULT YOUR LOCAL BUILDING CODES FOR ADDITIONAL INSTALLATION REQUIREMENTS.** The quality of the installation can affect the performance of this product. Ply Gem Windows warrants this product when mullied according to these instructions and installed according to the instructions adhered to each window. Ply Gem Windows accepts no responsibility for air or water infiltration above, under or around the window. Painting of any vinyl components will null and void all warranties.

**MULLING MUST BE COMPLETED BEFORE UNIT CAN BE INSTALLED INTO OPENING.**

**For questions, please contact Ply Gem Windows at 1-888-9PLYGEM.**

## 1500 Beveled Mull Kit Components

*Mull kit contains gusset plates and mull bridges that will not be used depending on type of nail fin ordered.*

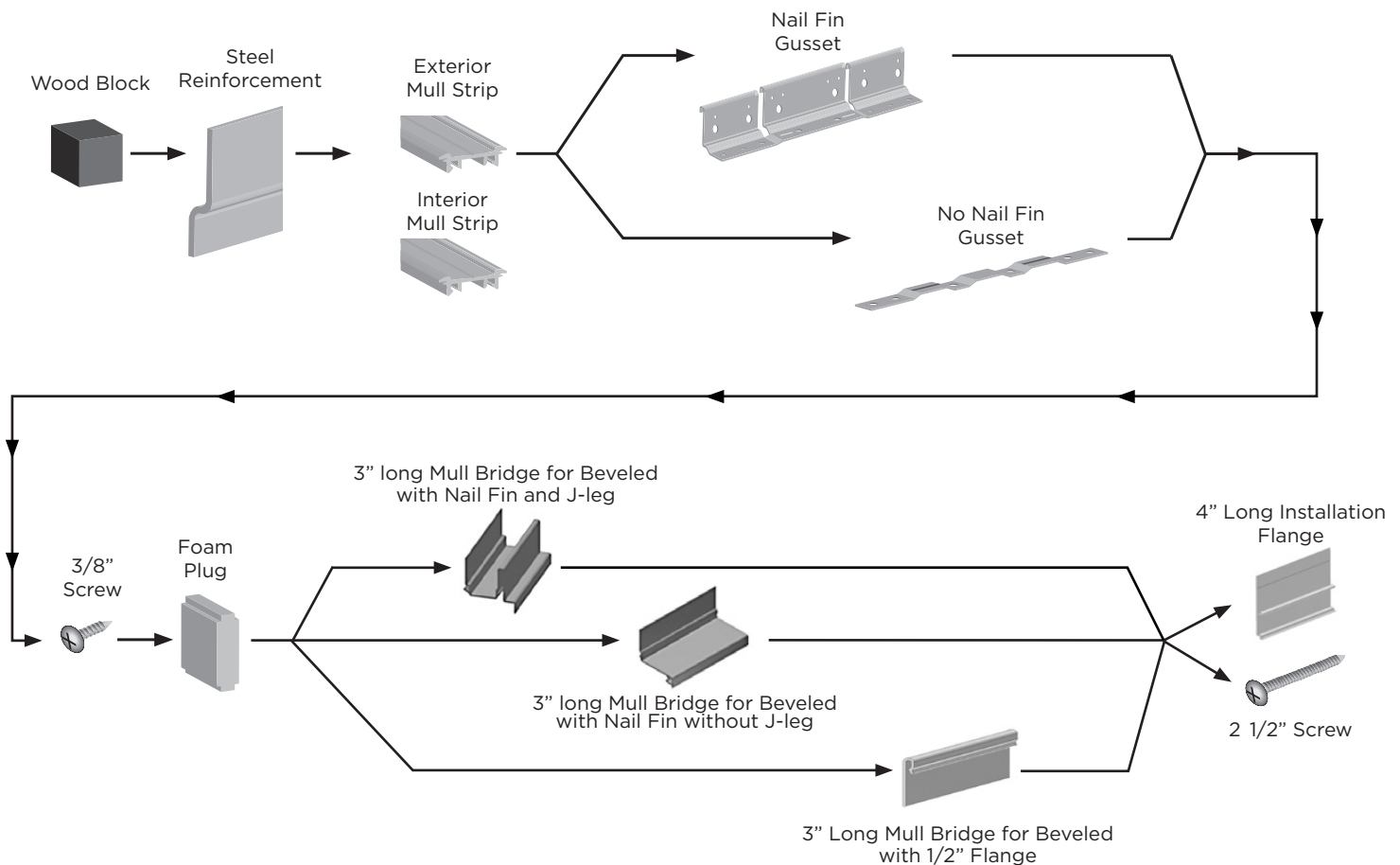

1. Place both windows to be mullied with the **INTERIOR SIDE UP** on a sturdy, flat work surface. For vertical mulls, arrange windows so the tops are aligned on one end and the sills are aligned on the other end to avoid mulling one of the windows upside down (**Figure 1**).
2. Remove any jamb centering clips from the side of the jambs to be mullied. Use a flat screwdriver to pry under the clip until the clip pops out of the frame. Jamb centering clips may be discarded.
3. Using a utility knife, score the base of the nail fin to be removed several times along the cutting line. Bend the nail fin up and down along this cut until it snaps off of the frame (**Figure 2**). **Any remaining fin over 1/16" tall must be trimmed off to prevent interference later with the steel reinforcement.**
4. If using a beveled frame with the integral J-leg, the J-leg to the exterior of the nail fin must also be trimmed off the frame edge to be mullied using the same removal technique as the nail fin.
5. The interior accessory groove corners to be mullied must be cleared of any remaining weld flash that may remain in the accessory groove. Be careful not to cut off the entire corner, but rather trim just the legs down to the base of the accessory groove (**Figure 3**).
6. Trim off weld flash from the corner to be mullied in the pocket to the interior side of the nail fin (**Figure 4**). Weld flash must be trimmed to less than 1/8" tall to provide clearance for installing the gusset plate later.
7. Flip over each window so the **EXTERIOR SIDE IS UP**.
8. Clear any remaining weld flash from the exterior accessory groove corners to be mullied (**Figure 3**).
9. Trim off weld flash from the corner to be mullied in the J-pocket to provide clearance for the mull bridge (**Figure 5**).

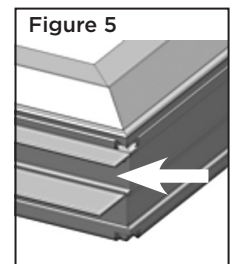
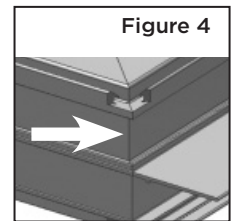
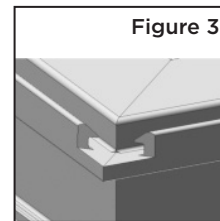
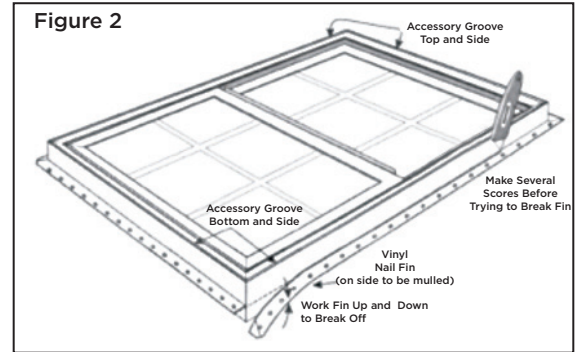
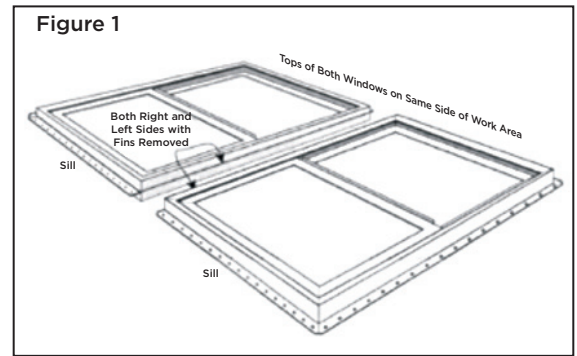

## **MULL EXTERIOR OF WINDOWS**

10. If window frames have a 1/2" flange applied, the ends must be trimmed back prior to mulling, or the 1/2" flange ends will collide at the top and bottom of the mull joint. Cut off the interfering 1/2" flange at the center of mull joint, an equal amount from each unit, until frames can be brought together with 1/2" gap between them (**Figure 6**).

**NOTE:** Use the mull strip included in the kit as a spacer to aid with keeping windows at 1/2" apart.

11. With the exterior side of the window facing up, apply a spot of sealant to one wood block and apply the block to the frame near the end of the pocket (**Figure 7**). The sealant will keep the block attached to the frame during the next steps.
12. Repeat for the block at the other end of the mull joint (**Figure 8**).
13. Select one piece of steel and ensure that it fits between these two wood blocks. Steel may be up to 4" short of touching the blocks. If steel is placed between the wood blocks and either block is protruding more than 1/8" over the edge of the frame, shave off some wood from the block until the steel fits, or cut steel shorter with a hacksaw.
14. Along the frame side from which the nail fin was removed, locate a wide pocket along the side. Find the groove at the base of that pocket (**Figure 9**, bottom black arrow). Slide the bottom edge of the steel into the frame groove as shown in the diagram, and then rotate the top of the steel up against frame (**Figure 9**, top gray arrow). Keep the steel from falling down temporarily with a short strip of duct tape.
15. Slide the second length of steel into the adjoining frame groove and apply duct tape again to keep steel against the frame.
16. Pull both window frames together. Be sure that the wood blocks at each end of the mull joint slide into the side pocket (**Figure 10**).
17. Beveled frame edges (**Figure 10**) should be 1/2" apart. Pull the duct tape out from between the steel bars and allow steel members to touch one another.
18. Verify that the mull strip length will reach from accessory groove to accessory groove (**Figure 11**). Cut the length to match **Figure 12** on each end.
19. Align the end of the mull strip to the inside edge of the accessory groove. Use a mallet (a hammer may crack mull strip) to insert two legs of the mull strip into the frame accessory grooves. Continue to snap in the mull strip along the entire length. No sealant is required.

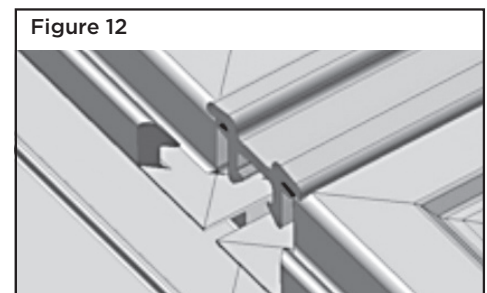
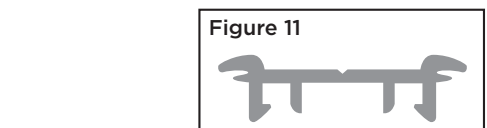
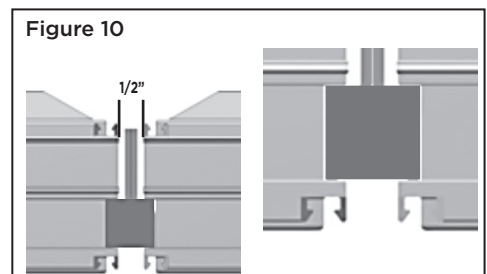
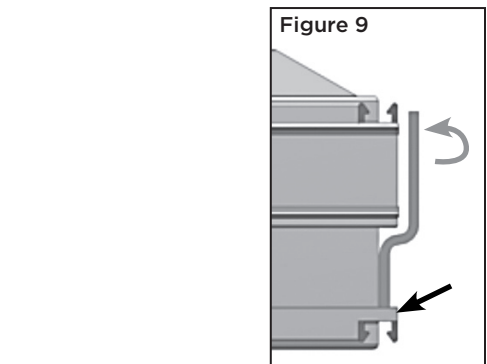
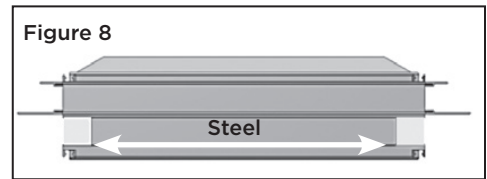
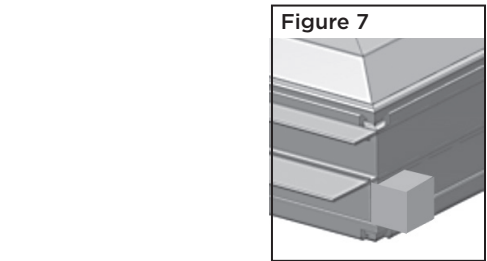
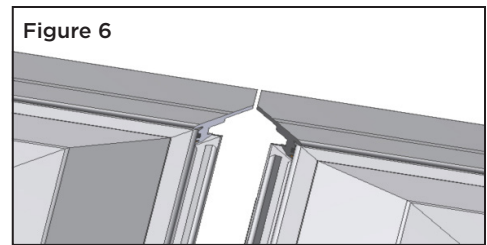

## **ATTACH GUSSET PLATES**

20. The mull kit contains two gusset plates (**Figure 13**). Every mull kit also contains two more gusset plates to be used for R&R (no nail fin) or 1/2" flange frame (**Figure 14**), which is used for either frame option.
21. Position the gusset plate over the joint.
- For a joint where both frame edges are in a straight continuous line (twin or triple or transom over a window), center the gusset plate over the mull joint (**Figure 13**).
  - For a special shape frame *with* a nail fin mulled over rectangular windows with nail fin, adjust the gusset plate down from centered over the joint by about 1-1/2" so the open slit in the gusset plate is positioned just above the mull joint. Bend the top section of the gusset plate back against the shape frame.
  - For a special shape frame *without* nail fin mulled over rectangular windows without a nail fin, center the gusset plate over the joint (**Figure 14**), and bend the top half of the gusset plate back against the shape frame.

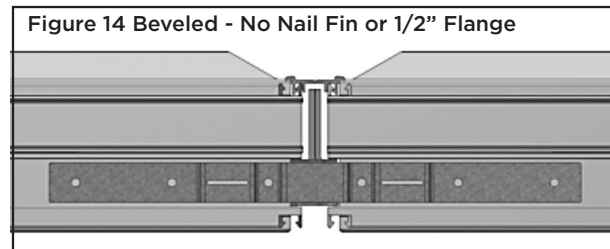
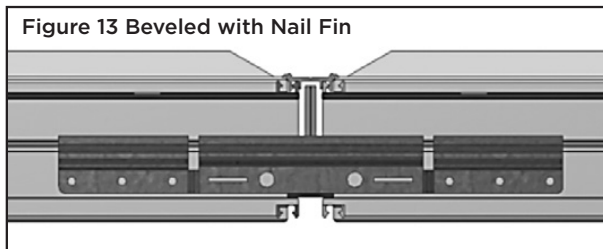

22. Verify that the gusset plate bottom sits flat against the frame. Weld flash might need to be trimmed away from the frame corners until the gusset plate lays flat against frame.
23. Drive the provided screws into the holes in the gusset plate.
- For the beveled frame with the nail fin gusset plate (**Figure 13**), drive six of the provided 3/8" panhead screws (**Figure 15**) into the three holes on each end of the gusset plate (**Figure 13**).
  - For the beveled frame option installed without a nail fin, as in R&R or 1/2" flange (**Figure 14**), drive six of the provided panhead screws (**Figure 15**) into each of the three holes on each wing (**Figure 14**).
24. Repeat the gusset plate attachment for the other side of the mull joint.

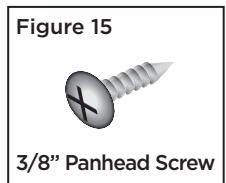

## **INSERT FOAM PLUG**

25. Use two foam plugs for the mull joint (**Figure 16**).

- a. Apply sealant to two opposite sides of the first foam plug (**Figure 17**). Insert the foam plug with orientation 1/2" wide x 1 3/8" tall, then insert 7/8" into the mull joint (**Figure 18**).
- b. Insert the foam plug gently so it stays square with the opening and does not rotate or fall into the void (remove with needle nose pliers and insert again if not flush). Continue to insert until foam is flush with bottom of J-pocket (**Figure 18** for frame with nail fin; **Figure 19** for R&R or 1/2" flange frame).
- c. Insert the second foam plug into the other side of the mull joint.

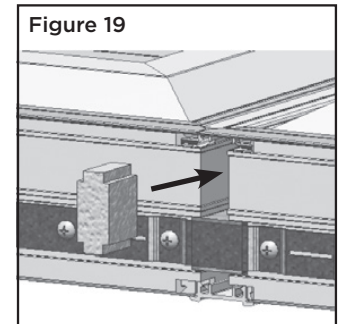
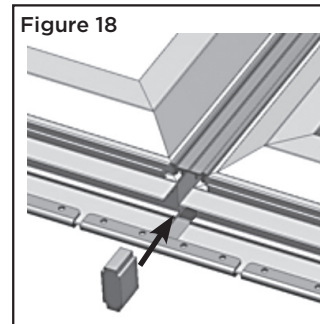
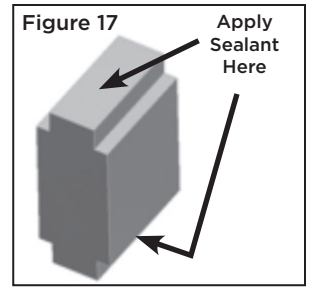
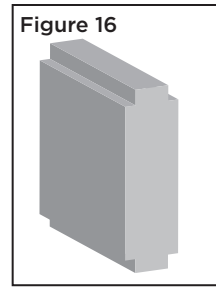

## **SEAL EXTERIOR MULL JOINT OF BEVELED FRAME**

26. Seal the beveled frame with nail fins and J-leg.

- a. Apply exterior-grade sealant following the path shown in **Figure 20**. Start an 1/8" diameter bead into 1 inch of the accessory groove, then over the end of the exterior mull strip, into 1 inch of the second unit's accessory groove, up and over the J-leg, across the base of the J-pocket, across the nail fin up to the gusset plate, across the gusset plate lip, then back to the starting point in the same fashion.
- b. Center the mull bridge (**Figure 21**) over the joint. Set the bridge over the J-leg, then slide it down into J-pocket, pushing bridge onto sealant bead (**Figure 22**).
- c. Remove the excess sealant with a clean cloth or paper towel and repeat for the other mull joint.

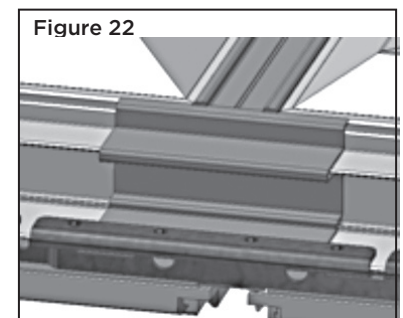
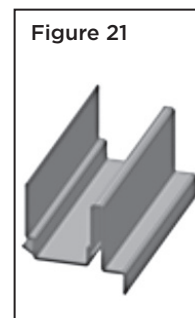
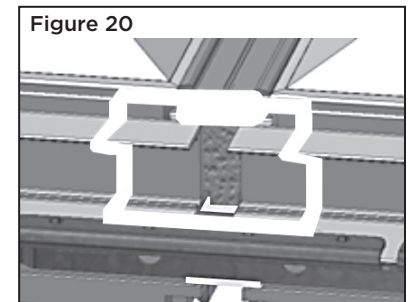



## SEAL EXTERIOR MULL JOINT OF BEVELED FRAME (continued)

27. Seal the beveled frame with nail fins without J-leg.

- a. Apply exterior-grade sealant following path shown in **Figure 23**. Start an 1/8" diameter bead into 1 inch of the accessory groove, then over the end of the mull strip, into 1 inch of the second unit's accessory groove, across the frame, across the nail fin up to the gusset plate, across the gusset plate lip, then back to the starting point in the same fashion.
- b. Center the mull bridge over the joint (**Figure 24**). Push the bridge into the accessory groove, then slide the part down against the nail fin and snap over the rib on the nail fin, pushing the part onto sealant bead (**Figure 25**).
- c. Remove the excess sealant with a clean cloth or paper towel and repeat for the other mull joint.

28. Seal the beveled frame with 1/2" flange option.

**NOTE:** If 1/2" flange has been applied to all four sides of the window frame, mulling will not be possible. Windows to be mulled must be ordered from the factory with the flange removed from the side to be mulled or flange must be cut at the corner welds and then rolled out of the frame in the field.

- a. Center the mull bridge over the joint and push mull bridge down over the joint (**Figure 26**). See **Figure 27** for view of properly positioned mull bridge.
- b. Flip the mull combination over so the **INTERIOR SIDE IS UP**.
- c. Apply 1/8" diameter bead of exterior-grade sealant starting at the accessory groove corner and then over the foam and across the mull joint through the second accessory groove. Next apply sealant to the triangular opening between the trimmed 1/2" flange ends (**Figure 28**).
- d. Remove the excess sealant with a clean cloth or paper towel and repeat for the other mull joint.

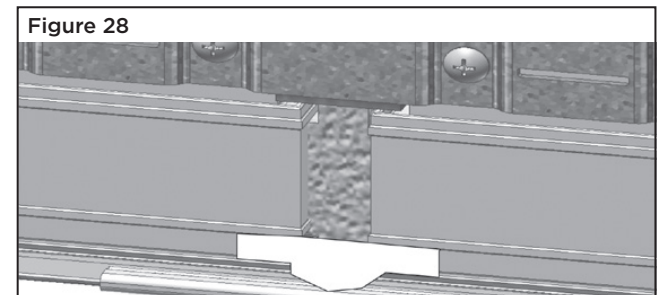
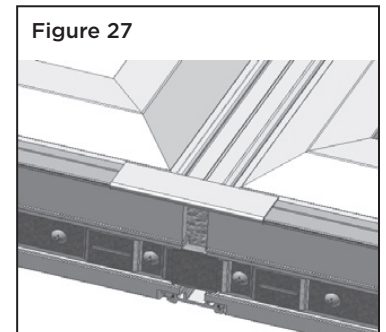
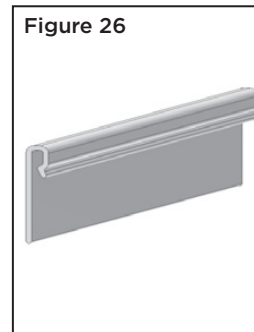
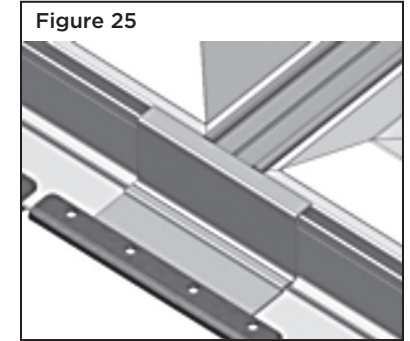
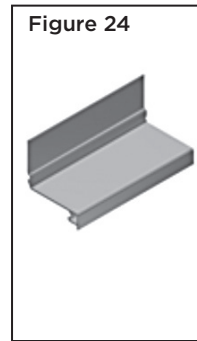
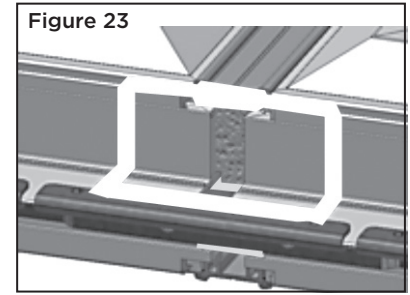

## **SEAL EXTERIOR MULL JOINT OF BEVELED FRAME (continued)**

29. Seal the beveled frame with no nail fins or flanges.
  - a. Apply exterior-grade sealant over the end of the mull strip and over the open ends of the accessory groove (**Figure 29**). Tool in sealant for a finished look.
  - b. Repeat for the other mull joint.
30. If further mullled joints are required (For example, if you are adding a third window to a twin to form a triple, or mulling a transom or shape over a twin), repeat all the steps above before proceeding.

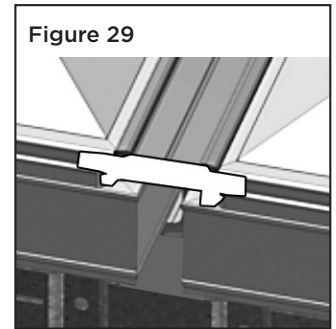

## **INTERIOR MULL JOINT**

31. After all mulling steps have been completed on the exterior surface of the combination, flip mullled combination over so **INTERIOR SIDE IS UP**. Be sure to hold the window frames firmly during the flip so that the frames do not separate on the interior side of the mullled joint. This step requires additional hands to control the weight and the unwieldy manner of the partially supported windows in the combination.
32. The mull strip provided (**Figure 30**) should be at least long enough to reach from the accessory groove on one side of the mull joint to the accessory groove on the other end of the mull joint (**Figure 31**).
33. Determine the length the interior mull strip must be, and cut to that length.
  - a. If using the Ply Gem drywall return, cut the mull strip to reach from the accessory groove on one side of the mull joint to the accessory groove on the other side of the mull joint.
  - b. If jamb extensions or drywall receivers will be used, allow space for that optional accessory along both edges and cut to desired length.
34. Align the cut end of the mull strip to desired location on interior mull joint. Use a mallet (a hammer may crack the mull strip) to insert two legs of the mull strip into the frame accessory grooves. Continue to snap in the mull strip along the entire length. No sealant is required on the interior side.

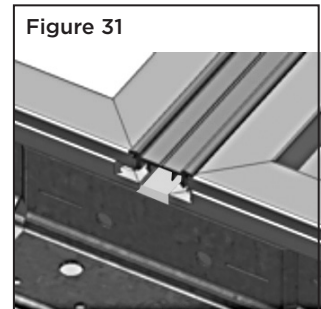
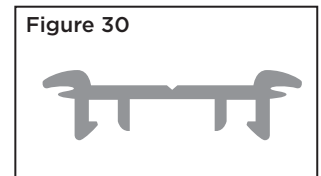

## **INSTALLATION OF MULLED COMBINATION**

35. Refer to the installation instructions located on the back of the label affixed to the glass of each window. Follow these instructions for preparation of rough opening, weather resistant barrier, pan flashing, sealing, shimming and fastening into rough opening.
36. Fasten the mulled joint to the rough opening.
- For frames with a nail fin, fasteners used to secure the vinyl nail fin to the rough opening are described in the **Fastener Schedule** on the same label. In addition to these fasteners, the steel gusset plates folded over the nail fin require eight screws (#8 x 2 1/2" panhead screws, included in each mull kit) to be driven through the eight holes in each gusset plate into the rough opening (**Figure 32**).
  - For frames with 1/2" flange using installation flanges, each mull kit includes four pieces of 4" long installation flanges to be used on each side of the gusset plate at both ends of the mulled joint. Refer to the installation instructions provided with the window on how to install and fasten to rough opening.

